



See Page 1 for
Quick Start Guide.

Song Meter SM3BAT

BIOACOUSTICS RECORDER

User Guide

Copyright ©2014-2018 Wildlife Acoustics, Inc. All Rights Reserved.

This documentation may not be reproduced or distributed in any form or by any means, graphic, electronic, or mechanical, including but not limited to photocopying, scanning, recording, taping, e-mailing, or storing in information storage and retrieval systems without the written permission of Wildlife Acoustics. Products that are referenced in this document such as Microsoft Windows® may be trademarks and/or registered trademarks of their respective owners. Wildlife Acoustics makes no claim to these trademarks. While every precaution has been taken in the preparation of this document, individually, as a series, in whole, or in part, Wildlife Acoustics, the publisher, and the author assume no responsibility for errors or omissions, including any damages resulting from the express or implied application of information contained in this document or from the use of products, services, or programs that may accompany it. In no event shall Wildlife Acoustics, publishers, authors, or editors of this guide be liable for any loss of profit or any other commercial damage caused or alleged to have been caused directly or indirectly by this document.

Wildlife Acoustics, Song Meter, Echo Meter, and Kaleidoscope are registered with the U.S. Patent and Trademark Office. SM1, SM2, SM2BAT, SM3, SM3BAT and WAC are trademarks of Wildlife Acoustics, Inc. All other trademarks are the property of their respective owners. The Song Meter is patented (U.S. Pat. No. 7,454,334 and 7,782,195). Additional U.S. and international patents and trademarks are pending.

Updated July 18, 2018

Contents

1	Quick Start Guide	1
2	SM3BAT Overview	2
2.1	Introduction	2
2.2	Updates and Support	2
2.3	SM3BAT Visual Tour.....	3
2.4	The LCD Main Menu	6
2.5	Basic Operation.....	7
3	SM3BAT Setup	8
3.1	Required Items.....	8
3.2	How to Connect Optional Microphones	8
3.3	How to Turn Power ON and OFF	11
3.4	How to Install Internal Batteries.....	12
3.5	How to Use the SM3BAT with External Power.....	13
3.6	How to Insert and Remove SD Memory Cards.....	14
3.7	How to Set the Date and Time.....	16
3.8	How to Set the Location and Time Zone	17
3.9	How to Set the Solar Calculation Method	18
3.10	How to set the Minimum Battery Voltage.....	18
3.11	How to set the Microphone Sensitivity	19
3.12	How to Change the Prefix for Recorded Files	19
3.13	How to Verify the Device and Audio Settings.....	19
3.14	How to Mount the Recorder.....	20
3.15	How to Check the Status of the Recorder.....	20
3.16	Temperature Sensor	21
3.17	The Backup Clock Battery	21
3.18	How to Connect the GPS Time-Synch Option	22
4	Programs	25
4.1	Introduction	25

4.2	Recording File Basics.....	25
4.3	How to Load a Built-In Program	26
4.4	How to Edit a Program	26
4.5	How to Create a Program On the Recorder	27
4.6	How to Export a Program.....	28
4.7	How to Import a Program	28
4.8	How to Start a Program.....	29
4.9	How to Stop a Program	30
5	SM3 Configurator Software	31
5.1	Introduction	31
5.2	How to Install the SM3 Configurator.....	31
5.3	How to Open the SM3 Configurator	31
5.4	SM3 Configurator User Interface.....	32
5.5	How to Create a Program (SM3 Configurator)	33
5.6	How to Adjust Configuration Settings.....	33
5.7	How to Adjust Deployment Scenario Settings	34
5.8	How to Use the Scrollable Calendar View	35
6	Developing Custom Programs	36
6.1	Loops	36
6.2	AUTO Values.....	36
6.3	Program Commands.....	37
6.4	How to Work With the Program Checker	45
6.5	How to Resolve Program Checker Errors	46
7	Managing Deployments	50
7.1	How to Estimate Battery Life	50
7.2	How to Estimate Memory Requirements.....	50
8	Audio Recordings	52
8.1	Filenames for Recordings.....	52
8.2	Recording Metadata	53
8.3	Summary Text Files	54

8.4	How to Install the Kaleidoscope Software.....	55
9	Utilities	56
9.1	How to Erase and Format SD Memory Cards	56
9.2	How to Reset Factory Default Settings.....	56
9.3	How to Measure Microphone Sensitivity.....	57
9.4	How to Update the Firmware	60
9.5	How to Generate Diagnostics	61
10	SM3BAT Specifications	62
10.1	Physical	62
10.2	Power.....	64
10.3	Memory Cards	64
10.4	Acoustic Audio	65
10.5	Ultrasonic Audio	65
10.6	Microphones.....	66
11	Warranty and Disclosures	72
11.1	Wildlife Acoustics, Inc. Limited Warranty	72
11.2	Declaration of Conformity (EN 45014)	73
11.3	Prohibition Against Eavesdropping	74
11.4	Electromagnetic Interference	74

1 Quick Start Guide

Complete the following checklist to start recording with the SM3BAT.

- ❑ Optionally, check for firmware updates for the SM3. See Section 9.4 for instructions.
- ❑ Install four (4) new high-quality D size alkaline or NiMH batteries in the two battery bays. See 3.4 How to Install Internal Batteries.
- ❑ Insert at least one (1) and up to four (4) memory cards. See 3.6 How to Insert and Remove SD Memory Cards.
- ❑ Slide the power switch down to turn **ON** internal battery power.
- ❑ Replace the memory bay cover and hand-tighten the four (4) thumb-screws.
- ❑ The device powers on and reports its status. After scanning the memory cards, the **Song Meter Main Menu** appears.
- ❑ Set the date and time. See 3.7 How to Set the Date and Time.
- ❑ For programs based on sunrise or sunset, set the recorder location and time zone. See 3.8 How to Set the Location and Time Zone.
- ❑ Load a built-in program. See 4.3 How to Load a Built-In Program.
 - Use *Sunset to Sunrise* to record triggered .wav files.
 - Use *Sunset - Sunrise ZC* to record triggered zero crossing.
- ❑ You may modify a built-in program on the recorder, but it is recommended to use the SM3 Configurator software on your computer. See Chapter 5.
- ❑ Mount the recorder in a suitable location for unattended recording.
- ❑ Connect one or two SMM-U1 ultrasonic microphones. The recorder automatically detects the microphones and records on those channels.
- ❑ Press the **PROGRAM START** button to start the active program on the recorder. The SM3BAT knows when to enter sleep mode to save power and is smart enough to wake itself to record for the duration of your deployment.
- ❑ (Optional) During deployment, press **CHECK STATUS** to check battery voltage or remaining memory card capacity.
- ❑ Hours, days, or weeks later, press and hold **PROGRAM STOP** for two seconds to finish recording. Remove the memory cards and review the recordings on your analysis workstation or another computer.

2 SM3BAT Overview

2.1 Introduction

The Song Meter SM3BAT is a cost-effective, and reliable solution for the periodic, seasonal, or long-term acoustic monitoring of bats, birds, frogs, and other wildlife in any field conditions.

You can program the device to record when you want for as long as you need. The SM3BAT has the battery life and memory capacity to record for hundreds of hours and can be used outdoors for extended durations lasting days, weeks, or even months at a time. Take the rugged heavy-duty portable device with you anywhere or mount it in a fixed outdoor location.

The SM3BAT combines a two-channel full spectrum recorder and a two-channel zero-crossing recorder in one box. Record full spectrum up to 384 kHz sample rate on one channel and up to 256 kHz on two channels (192 kHz in WAC mode) simultaneously. You can also record zero crossing on one or two channels and at the same time as recording full spectrum.

2.2 Updates and Support

SM3BAT is field-upgradeable. New features, fixes, and improvements are available in firmware updates from our website. The *SM3 Configurator* software notifies you when new firmware is available. See 9.4 How to Update the Firmware on page 60.

2.2.1 How to Join Our Mailing List

Join our mailing list to receive important news and information about your Song Meter and related products, features, and events.

1. Navigate to www.wildlifeacoustics.com.
2. Click **Contact Us**.
3. Click **Join Our Mailing List**.

2.2.2 How to Contact Support

We have full-time support staff ready to assist you.

- Email: support2018@wildlifeacoustics.com
- In the United States (toll-free): 1-888-733-0200
- Outside the United States: +1 978-369-5225

2.3 SM3BAT Visual Tour



Song Meter SM3BAT Product Diagram

1	Mounting Options (Top and Bottom): Constructed of rugged die-cast aluminum and ready for outdoor adventure, use these cutouts to mount your SM3BAT in almost any land environment for a wide range of applications.
2	Keypad: Press the buttons on this panel and view the menu options on the LCD screen and control the unit.
3	Pressure Vent: This temperature, UV, and water-resistant vent protects the enclosure against condensation, moisture, and heat exposure.
4	Battery Bays: Each bay holds two D batteries. Spring-loaded ergonomic caps turn left to open and right to close.
5	Memory Bay: Insert up to four SDHC or SDXC memory cards. Supports cards up to 2 TB (currently 256 GB is the maximum capacity being manufactured). Sturdy cover and four easy-grip thumb-screws offer superior protection. Remove the cover to access the SD card slots and power switch.

- | | |
|---|--|
| 6 | Channel 0 Microphone Connector: Connect an SMM-U1 ultrasonic microphone, SMM-A1 acoustic microphone, or SM3-H1 hydrophone. |
| 7 | Channel 1 Microphone Connector: Connect an SMM-U1 ultrasonic microphone, SMM-A1 acoustic microphone, or SM3-H1 hydrophone. |
| 8 | Serial Communication Connector: For the optional GPS time-synch receiver or the available Song Stream remote access hardware. |
| 9 | External Power Cable and Audio Output Connector: Use for external batteries (with or without solar panels). |

All batteries, memory cards, LCD display, and electronic controls are mounted inside the weather-resistant enclosure to protect them from the elements.

NOTE: Do not remove the back cover of your recorder. There are no user-serviceable parts and removing the cover will void your warranty. When necessary, only remove the thumb-screw cover for the memory bay, the two twist-off battery bay covers, and the four connector module caps.



Each of the four connectors provides a weatherproof seal when mated with a microphone cable or with the watertight connector caps. Connector caps protect the connector port from moisture and debris. Always cap unused connectors. Push a cap over each exposed connector until fully seated and secure.

CAUTION: Gently, but firmly, hand-tighten all covers, caps, and connectors to completely secure the device against the environment before use. Do not use tools or apply too much pressure since over-tightening could damage the recorder.

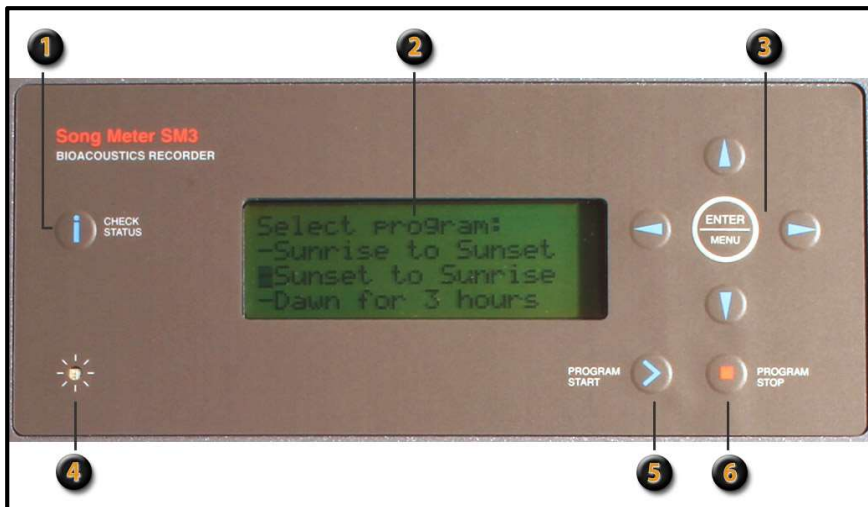



SM3BAT LCD Display and Buttons

- 1 **Check Status:** Displays the status of the device and illuminates the LCD screen backlight for visibility in dark or low-light environments. Remains lit while you continue pressing buttons to operate the device. Turns off after 5 seconds of inactivity.
- 2 **LCD Screen:** Displays the main menu, status information, and other details when the recorder is awake. Blank when the unit is sleeping to save power.
- 3 **Main Navigation Buttons:** Press the directional arrow buttons on this panel and view the menu options on the LCD screen to control the unit. Press ▲ **Up** or ▼ **Down** to navigate lists of options. Press ► **Right** to advance to the next submenu or value. Press ► **Right** to save your changes. Press ◀ **Left** to cancel or go back to the last menu item. Press **ENTER/MENU** to navigate menus, select options, and to confirm entries.
- 4 **LED Indicator:** Flashes  green once per second when recording. Flashes  red once per second when triggers are enabled and the recorder is awake and armed, but not currently recording. To disable see Section 6.3.
- 5 **Program Start:** Closes any open menus and starts your current program. Depending on the schedule, the device may begin recording immediately or go to sleep until a scheduled recording event. If a program is already running, pressing this button does nothing.
- 6 **Program Stop:** Stops the active program and returns to the main menu. You may need to hold the button for a couple seconds to register in some modes. In an open menu, pressing this button does nothing.

2.4 The LCD Main Menu

Refer to the following table when navigating the main menu using the LCD screen and directional buttons.

Recorder Main Menu on the LCD Screen

Menu Item	Description
Program	
Load Program	Choose a ready-to-run (and customizable) built-in program.
Edit Program	Edit, add, or delete command lines in a program.
Import Program	Import a program and associated settings from an SD card.
Export Program	Export a program and associated settings to an SD card.
Settings	
	(Optional) You can also use the SM3 Configurator software to override the settings on any SM3BAT device.
Sunrise/Sunset Type	Specify one of four recognized methods for calculating the sunrise and sunset.
Location	Specify the location using a prefix, Lat/Long, and time zone.
Prefix	Specify a short code to identify recordings from a specific program, project, location, or SM3BAT device; useful to project teams with multiple recorders.
Latitude	Specify the latitude of the SM3BAT anywhere on the globe in degrees north (N) or south (S) of the equator. Latitude is used in sunrise and sunset time calculations.
Longitude	Specify the longitude of the SM3BAT anywhere on the globe in degrees west (W) or east (E) of the Prime Meridian (Greenwich). Longitude is used in sunrise and sunset time calculations.
Timezone UTC	Set the global time zone for your device.
Time and Date	Set the local date and time for your device.
Power Volt Cutoff	Specify a minimum voltage from 0.0 to 12.0 volts in 0.1 volt increments. If the battery voltage falls below this value, the recorder will go to sleep, checking the battery voltage again every 24 hours and waking up if it rises above the cutoff. Use only with external batteries to protect certain battery types from over-discharge..
Ch 0 Sensitivity	Specify channel 0 microphone sensitivity from 0.0 to -299.9 dB in 0.1 dB increments. This value is saved in the recording metadata and may be used in future features.
Ch 1 Sensitivity	Specify channel 1 microphone sensitivity from 0.0 to -299.9 dB in 0.1 dB increments. This value is saved in the recording metadata and may be used in future features.
Utilities	
Export Diagnostics	Display useful status and troubleshooting information.
Set Factory Default	Reset the original device settings.
Calibrate Mics	Test the sensitivity levels of built-in and connected mics.
Format All Cards	Erase and reformat all SD cards. The original file system such as exFAT or FAT32 is preserved. CAUTION: All data on all memory cards is permanently lost and cannot be recovered.
Firmware Update	Update the recorder with a new firmware file in memory slot A.

2.5 Basic Operation

Typical operation of the recorder is represented in the following steps:

1. Configure the following key requirements of any deployment with your specific recording goals in mind:
 - a. **Power:** Insert batteries or connect another power source.
 - b. **Memory:** Insert and format memory cards.
 - c. **Location:** Identify an appropriate recording location and establish mounting requirements for the duration of the deployment.

TIP: Use the *SM3 Configurator* software to estimate memory card requirements and power consumption for the program that you plan to run.

2. Load a program on the recorder. You can choose:
 - a built-in program already on the recorder
 - a program you edit on the recorder
 - a custom program that you design using the SM3 Configurator software and then import to the recorder on a memory card.
3. Mount and secure the recorder.
4. Press the **PROGRAM START** button. You can leave the recorder unattended after this step.
5. The recorder *sleeps* until the next scheduled recording time.
6. The recorder *wakes* at the scheduled recording start time, records audio as programmed, and saves recordings on one or more memory cards.
7. After a period of time has elapsed (it might be several days, weeks, or even months), return and check on each recorder. To extend a deployment, exchange memory cards and install fresh batteries out in the field.
8. At the end of the deployment, remove the device from its mounted location, eject all memory cards, and examine the recorded output.
9. Clean, re-program, and prepare the recorder for its next assignment.

3 SM3BAT Setup

3.1 Required Items

You need at least the following required items to operate the recorder:

- **Memory Card** for installing firmware updates and saving audio files. Insert at least one (1) and up to four (4).
- **Power Source** to power the recorder. Choose four (4) D-size batteries or an external power cable to an external power source.
- **Program File** to determine when to record and other settings. Choose one of the built-in programs or your own custom program.
- **Ultrasonic Microphone** to capture bat recordings. Connect one (1) or two (2) ultrasonic microphones.

NOTE: With an optional acoustic microphone, the SM3BAT recorder is also capable of recording non-ultrasonic wildlife such as birds or frogs.

3.2 How to Connect Optional Microphones

You can connect one or two external microphones. The two microphone connectors for channel 0 and channel 1 mate directly with the 3m cable included with the ultrasonic (SMM-U1) or acoustic (SMM-A1) microphones available from Wildlife Acoustics.

NOTE: Unauthorized devices may damage the recorder and will void the warranty.

Both microphones can be extended with available extension cables in 10m and 50m lengths. All connections are fully waterproof. The connector on the cable is keyed and the cable should be seated into the connector when oriented correctly and then locked into place by turning the locking ring on the microphone or cable ⤵ clockwise firmly until it stops.

NOTE: Each cable is shipped with a ferrite filter to reduce electromagnetic transmission to nearby equipment. This is required to comply with FCC regulations but not installing will not adversely affect the performance of the recorder. The ferrite should be installed to the cable that attaches to the recorder. The cable is looped through and the ferrite snapped shut. A zip tie is included for further securing the filter.

NOTE: Mounting cabled microphones on ungrounded non-conductive masts especially in dry and windy conditions, could result in damage to the microphones or recorder due to electrostatic build up or lightning. Such damage is not covered under warranty so please check with a professional/licensed electrician or installer of outdoor antennas, weather instruments or the like for advice suitable to your specific situation.

3.2.1 SMM-U1 Ultrasonic Microphone

The SMM-U1 is a highly sensitive and low noise ultrasonic microphone designed for recording ultrasound up to 190 kHz. One or two microphones can be attached via the connector module.

NOTE: The discontinued SM3-U1 Ultrasonic Microphone is electronically identical to the SMM-U1, but comes in a larger plastic microphone enclosure. All the information in this section also applies to the SM3-U1.

The SMM-U1 is a powered microphone and can be used with up to 100 meters of cable with no attenuation or degradation. The microphone has a differential output, which significantly reduces noise from electromagnetic sources.

The omnidirectional SMM-U1 is ideal for unattended monitoring where the precise direction of bat activity is not known in advance. See the specifications chapter for polar plots. For applications requiring directionality, the microphone can be adapted for directional sensitivity with the available SM3 Horn Attachment.

The SMM-U1 microphone features a hydrophobic membrane transparent to acoustic or ultrasound signals to prevent unpressurized water from entering the microphone. In gusty windblown rain, water may pass the membrane and the included windscreen should be installed so as to protect the internal ultrasonic transducer from water damage. We also recommend positioning the microphone so that they point parallel to the ground, or even slightly downward, so as to minimize water entry.



3.2.2 How to Connect the SM3-Horn Attachment

The available SM3 Horn Attachment turns our SMM-U1 omnidirectional ultrasonic microphone into a highly directional microphone, while preserving call quality. The attachment remains weatherproof at angles up to 45-degrees.



3.2.3 Installing Microphone Windscreens

Windscreens should be installed on SMM-U1 microphones for long-term deployments in all areas susceptible to heavy wind driven rain. This could result in permanent damage to the microphone element due to water penetration. The risk is greater when deployed with the ultrasonic horn attachment. For short-term deployments with predictions of less severe weather and in dry climates, you can avoid using windscreens.

The windscreens will attenuate ultrasound by only a few dB when dry. However, they will block most ultrasound when soaked with water, until they dry. Drying time can vary significantly based on temperature, humidity and wind.

Secure the windscreens for the SMM-U1 microphone with the included C-clip. Make sure there is an air gap between the windscreen and the microphone as shown below. (Do not pull the windscreen down tightly).

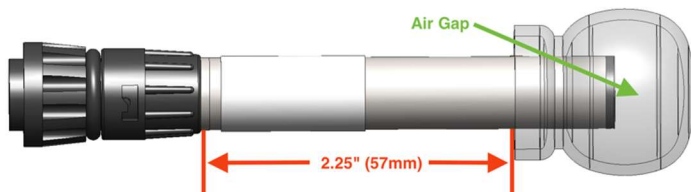

For the SMX-Horn directional attachment, secure the large windscreen with the included zip-tie as shown below. Exact positioning is not important.



3.2.4 SMM-A1 Acoustic Microphone

A cabled SMM-A1 acoustic microphone is also available (sold separately). This microphone shares the same high-quality acoustic recording element as the SM3 recorder. It is completely weatherproof and can be deployed away from the recorder with cables up to 100 meters in length. You can attach one or two.



3.2.5 SM3-H1 Hydrophone

The SM3BAT recorder can also be used with an available hydrophone, the SM3-H1, for making underwater recordings. The hydrophone ships on a 20 meter cable and attaches to an adapter, which attaches to the same connectors as the cabled microphones.

An ultrasonic hydrophone to record dolphin echolocations is also available.

3.3 How to Turn Power ON and OFF

You can set the power selection switch to use internal power from four (4) D-size alkaline or NiMH batteries or external power through the connector port. The power selection switch is located in the memory bay.

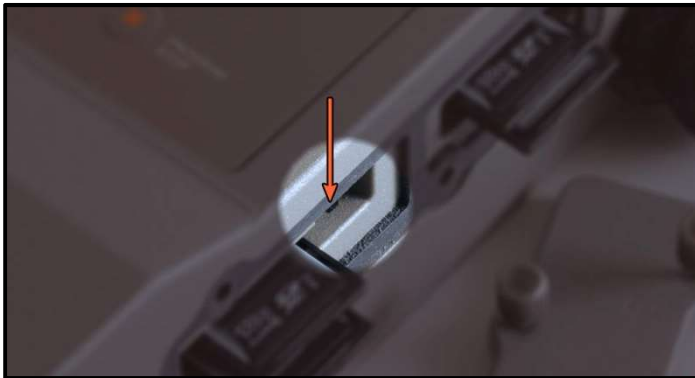

Set the power switch down to turn the unit **ON** using internal battery power. When not in use, set the switch up to conserve battery power. The up position also enables external power, if connected. When no external power exists, consider the up position to be **OFF**.

NOTE: Do not turn the power **OFF** when a recording is in progress. To safely exit from recording, press **STOP PROGRAM**, allow the recorder to return to the main menu, and then power down the device.

NOTE: Avoid quickly switching power **OFF** and then **ON** again. The unit can interpret this sudden loss and restoration of power as an error and may start diagnostics.

When you turn the power **ON** the following LCD screen appears:

2014-Jan-31	09:00:00
SM3 99999	ULT R1.0.3
A: 2/128	B: 0/128
C: 0/128	D: 0/128

The same information appears when the unit wakes from sleep and starts itself as programmed. The startup screen shows the following information:

- The current date in YYYY-MMM-DD format.
- The current time in HH:MM:SS format.
- The model number and serial number for the recorder.
- ULT appears only on SM3BAT models with ultrasonic features.
- The firmware version. For example, R1.0.3.
- For each card slot (A, B, C, and D) the memory used as a fraction of the total capacity in GB.

NOTE: *WP* will appear in place of the consumed memory for any card with a write-protection switch ON.

3.4 How to Install Internal Batteries

Set the power switch down to turn the unit **ON** using internal battery power. When not in use, set the switch up to conserve battery power. The up position also enables external power, if connected. When no external power exists, consider the up position to be **OFF**.

With normal operation and high quality alkaline batteries, the SM3BAT can record approximately 18 nights of full spectrum triggered recordings and approximately 20 nights of triggered zero crossing recordings on one channel. The device enters a very low power state when not recording and uses negligible power between scheduled recordings.

The recorder can be powered from four standard D size disposable alkaline batteries or rechargeable NiMH batteries.

1. Purchase four (4) new size D batteries of the same type. Alkaline batteries are recommended.

NOTE: Prior to installation, we recommend that you test all batteries with a high-quality pulse load battery tester such as the ZTS MINI-MBT.

2. Position your thumb and index finger into opposing bevels of one of the twist-off battery bay covers.
3. Rotate the cover up to 90 degrees ⤴ counterclockwise to remove it. The spring-loaded cover opens and the old batteries emerge.
4. Remove the two old batteries and insert two new batteries with the (+) positive ends up toward the cover as shown below.
5. Align the notches and then turn the cover 90 degrees ⤵ clockwise, but no more than 90 degrees. Delicate force is required to seal the cover.
6. Repeat for the two batteries in the other battery bay.



3.5 How to Use the SM3BAT with External Power

With the optional external power cable, the power connector can safely accept voltages from 5-17 volt DC and is intended for 6 or 12 volt external battery systems.

CAUTION: If you are unfamiliar with configuring external battery and power systems, you might want to consult with a local installer for assistance.



The SM3BAT provides protection against accidental reverse polarity connections. The power cable includes both F2 sized spade connectors and ring terminals to attach to a large 6 or 12 volt battery.

NOTE: Each power cable is shipped with a ferrite filter to reduce electromagnetic transmission to nearby equipment. This is required to comply with FCC regulations but not installing will not adversely affect the performance of the recorder. The ferrite should be installed to the cable that attaches to the recorder. The cable is looped through and the ferrite snapped shut. A zip tie is included for further securing the filter.

Set the power switch up to turn the unit **ON** using external battery power. When not in use, set the switch down to conserve battery power. The down position also enables internal power, if connected. When no internal power exists, consider the down position to be **OFF**.

See section 3.10 for information on setting a minimum voltage to prevent damage to lead acid batteries not designed for deep discharge.

3.6 How to Insert and Remove SD Memory Cards

Insert a card in slot A to update the firmware, import or export a program. Replace cards when all storage space is consumed by recordings. You can insert up to four (4) cards.

NOTE: Be sure the card's write protection switch is "off". The SM3 will not record to a write-protected card.

1. Turn the four thumb-screws ↺ counterclockwise to remove the memory bay cover. You may need to clear any debris, sand, or dirt that may have accumulated along the sealed edges.
2. Refer to the embossed letters A, B, C, and D on the cover to identify each card slot (also shown below).
3. To remove a card, lightly push it forward and then feel it release from the slot and pull it out.
4. To insert a card, lightly push it forward until each card is secure. Insert at least one card and up to three additional cards.
5. Turn the four thumb-screws ↻ clockwise to tighten and re-apply the cover.

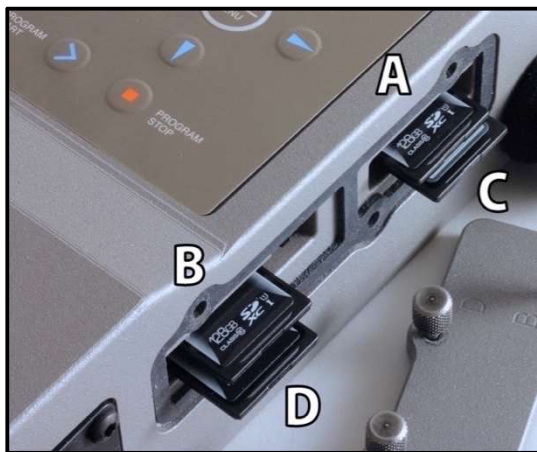

TIP: Insert multiple SD memory cards to take advantage of failover capabilities. If an error occurs on one card, the SM3BAT can continue writing data on another card.

If the recorder is unable to write to all available SD cards, one of the following errors appear:

```

2016-Jan-31 09:00:00
CARDS FULL, ERROR, or DIRTY
0: 24000 --- -----
1: 24000 --- -----
    
```

A card marked "DIRTY" indicates that a critical write operation affecting the file system (typically at the very beginning or ending of a recording) was interrupted due to an unrecoverable error or power failure. The Song Meter SM3 will avoid further use of a "DIRTY" card to avoid further card corruption that could lead to unrecoverable data loss. "ERROR" indicates some other flash card problems. The "DIRTY" condition can be cleared by accessing (writing) the card on your host computer or by reformatting the card using the SM3 on-board formatting utility.

NOTE: During a recording, do not remove memory cards. Replace cards only when the unit is in sleep mode or when power is **OFF**. In some cases, removing and/or inserting a memory card while the device is recording (often called *hot-swapping*) may cause the recorder to restart.

3.7 How to Set the Date and Time

You can set the current date and time for the recorder.

NOTE: The recorder does not automatically adjust for daylight savings time.

As you adjust the month and day, the unit calculates and displays the next sunrise and sunset times for your reference.

As you adjust the month and day, the unit calculates and displays the next sunrise and sunset times for your reference.

1. At the **Song Meter Main Menu**, select **Settings**, and press **ENTER/MENU**.
2. Select **Time and Date** and press **ENTER/MENU**.
The date and time appear on one line in the following format:
YYYY-MMM-DD HH:MM:SS
For example:

2015-Oct-22	20:17:45
-------------	----------
3. Press **ENTER/MENU** or **▶ Right**.
The cursor flashes on the last digit of the year.
4. To adjust the year, press **▲ Up** or **▼ Down**.
5. Press **ENTER/MENU** or **▶ Right** to set the month.
6. To adjust the month, press **▲ Up** or **▼ Down**.
7. Press **ENTER/MENU** or **▶ Right** to set the numeric day of the month.
8. To adjust the date, press **▲ Up** or **▼ Down**.
9. Press **ENTER/MENU** or **▶ Right** to set the hour.
10. To adjust the hour, press **▲ Up** or **▼ Down**.
11. Press **ENTER/MENU** or **▶ Right** to set the minute.
12. To adjust the minutes, press **▲ Up** or **▼ Down**.
13. Press **ENTER/MENU** or **▶ Right** to set the second.
14. To adjust the seconds, press **▲ Up** or **▼ Down**.
At this point in the procedure, you have explored all of the options for changing date and time values.
15. (Optional) To go back and make any changes, press **◀ Left**.
Press **▶ Right** to return to the seconds value.
16. Press **ENTER/MENU** or **▶ Right** to apply your changes. The cursor moves back to the first digit of the year and then applies your changes.

17. Press ◀ **Left** two times to return to the main menu.

NOTE: To accelerate the pace when adjusting the date and time values, press and continue to hold down the ▲ **Up** or ▼ **Down** arrow buttons.

3.8 How to Set the Location and Time Zone

The selections you make for latitude, longitude, and time zone (in conjunction with the sunset/sunrise solar calculation type) enable the recorder to make adjustments and determine a specific sunrise and sunset time for each day.

NOTE: When you import a program with custom coordinates, a new prefix, UTC settings, and other check box items from the **Configuration Settings** section of the *SM3 Configurator* software, the new values from the program automatically replace the original settings on the recorder.

You can specify the local time zone (as used to set the clock) in hours relative to UTC (Universal Time Coordinated). Half and quarter time zones (:00, :15, :30, :45) are also supported.

NOTE: The recorder does not automatically adjust for daylight savings time.

Use the following steps to set the latitude, longitude, and time zone.

1. At the **Song Meter Main Menu**, select **Settings**, and press **ENTER/MENU**.
 2. Select **Location** and press **ENTER/MENU**.
 3. On the **Location Settings** screen, press ▼ **Down** to select **Latitude**.
 - a. Press ► **Right**.
 - b. To enter degrees of latitude north of the equator, press ▲ **Up**.
 - c. To enter degrees of latitude south of the equator, press ▼ **Down**.
 - d. Press ► **Right** to enter minutes.
 - e. Press **ENTER/MENU**.
 4. On the **Location Settings** screen, press ▼ **Down** to select **Longitude**.
 - a. Press ► **Right**.
 - b. To enter degrees of longitude west of the prime meridian, press ▲ **Up**.
 - c. To enter degrees of longitude east of the prime meridian, press ▼ **Down**.
 - d. Press ► **Right** to enter minutes.
 - e. Press **ENTER/MENU**.
 5. On the **Location Settings** screen, press ▼ **Down** to select **Timezone**.
 - a. Press ► **Right**.
 - b. To specify one of the time zones ahead of 0:00 UTC, press ▲ **Up**.
 - c. To specify one of the time zones behind 0:00 UTC, press ▼ **Down**.
 - d. Press ► **Right** to specify additional 15-minute increments adopted by certain regions between two time zones.

- e. Press **ENTER/MENU**.

3.9 How to Set the Solar Calculation Method

Song Meter can be used to schedule recordings relative to sunrise and sunset times, and adjusts these times as they change during the year. You can choose from four different recognized methods of calculating the sunrise and sunset.

1. At the **Song Meter Main Menu**, select **Settings**, and press **ENTER/MENU**.
2. Select **Sunrise/Sunset Type** and press **ENTER/MENU**.
3. At the **Sunrise/Sunset Type** menu, the **Solar** item is already selected.
4. Press **▶ Right** to advance to the current solar calculation method.
5. Press **▲ Up** or **▼ Down** to advance through the following list of choices:
 - **Sunrise/set**: The sun is just below the horizon.
 - **Civil**: The sun is 6 degrees below the horizon.
 - **Nautical**: The sun is 12 degrees below the horizon.
 - **Astronomical**: The sun is 18 degrees below the horizon.
6. The calculated sunrise and sunset times for the method that you select appear as if they were occurring today. For example:

Sunrise/Sunset Type	
-Solar	Nautical
Rise 05:12	Set 18:57

7. Press **ENTER/MENU** to save your changes.
8. Press **◀ Left** to return to the **Song Meter Settings** menu.

NOTE: Sunrise and sunset calculations require other settings including your location (latitude and longitude) and time zone.

3.10 How to set the Minimum Battery Voltage

The Power Volt Cutoff setting allows you to specify a minimum voltage from 0.0 to 12.0 volts in 0.1 volt increments. If voltage falls below this value in a 24-hour period, the program is suspended.

This allows a minimum voltage to be set such that certain types of external batteries such as some types of lead acid batteries will not be damaged by over-discharge. This should not be used with internal alkaline batteries. These batteries are not rechargeable and are not damaged by complete discharge. Adding a minimum voltage with these types of batteries will result in decreased battery life as the recorder will suspend operation prematurely.

3.11 How to set the Microphone Sensitivity

The Ch 0 and Ch 1 Sensitivity settings should be ignored. These do not need to be set for the recorder to function properly and they do not set sensitivity. They allow known microphone sensitivities to be entered, which will be saved in the recording meta-data for use in undeveloped features.

3.12 How to Change the Prefix for Recorded Files

You can specify a filename prefix of up to 12 characters that appears in the recording file names to label every recording made by a specific program or recorder. For example, you can use one prefix (PROJECT-01) in a single program to tag all recordings from all devices linked to that single program or project. Or, you can use multiple unique prefixes on each recorder to tag recordings by location and device.

NOTE: The prefix can only contain capital letters, numbers, and hyphens.

The default prefix set by the hardware is the serial number of the recorder. You can edit this value on each device or override the prefix with a new one in the program file that you create using the *SM3 Configurator* software.

1. At the **Song Meter Main Menu**, select **Settings**, and press **ENTER/MENU**.
 2. Select **Location** and press **ENTER/MENU**.
 3. At the **Location Settings** menu, select **Prefix**, and press **► Right**.
 4. Specify a 1 to 12 character prefix:
 - a. At the first position, press **▲ Up** to cycle through the alphabetic characters A to Z. Press **▼ Down** to cycle through the numbers 9 to 0. You can also select a hyphen.
 - b. Press **► Right** to advance to the next position in the prefix and repeat the previous step.

3.13 How to Verify the Device and Audio Settings

A quick way to test the device is to load the built-in 24-hour recording program. Complete the following steps to verify the recorder is working.

1. Press **CHECK STATUS** two times in sequence.
 2. Verify that Mic0 and Mic1 show all attached external microphones.
 3. Perform the calibration procedure to verify that the microphones are picking up sound. See 9.3 How to Measure Microphone Sensitivity.
 4. Insert an SD card into one of the memory slots.
 5. Load the 24-hour recording program and press **PROGRAM START**.

6. You will see "ARMED" on the screen.
7. Make audible sounds (talk or clap hands) and ultrasonic sounds (jingle keys). You will then see "TRIGGERED" on the screen. One file will be created for each trigger.
8. After a few minutes of recording time, press **PROGRAM STOP**.
9. Remove the memory card and insert it in another computer, laptop, or mobile device.
10. View the recorded .wav or .wac file spectrogram. The filename should include the prefix set on the device or set by the SM3 Configurator if you loaded a custom program. For example:

ARIZONA-1234_0+1_20160104_152209.wav

3.14 How to Mount the Recorder

Constructed of rugged die-cast powder-coated aluminum, the SM3BAT is weather-resistant to the specifications given in Chapter 10: SM3BAT Specifications. Use the top and bottom mounting receptacles for attaching the unit with cables, screws, radiator clamps, bungee cords, or other fasteners.

3.15 How to Check the Status of the Recorder

Use the following procedure to check the status of the recorder. Cargo, including the recorder, can shift during transit. Always perform this procedure to check the status of the recorder and memory cards before a deployment.

1. Press and hold down the **CHECK STATUS** button until the unit responds. This may take several seconds.
2. The LCD screen backlight illuminates and an initial status screen appears.

2015-Jan-31		09:03:48	
SM3	00123	ULT	R1.0.3
A:	2/128	B:	0/128
C:	0/128	D:	EMPTY

NOTE: *WP* will appear in place of the consumed memory for any card with a write-protection switch ON.

3. After a short delay, the screen resets and the backlight turns off to save power.

4. Press **CHECK STATUS** a second time before the unit goes back to sleep and a second status screen appears after the first one. This screen shows the current battery voltage and temperature.
 - a. In this example, the unit is not currently recording; however, it has been programmed to start recording at the date and time shown:

```
Bat 5.9V      Temp 16.70
Mic0: U1     Mic1: NA
Next recording at:
2016-Feb-01 05:30:00
```

- b. In this example, the unit is currently recording on microphone 1 at a sound level of 41.1 dB.

```
Bat 5.9V      Temp 16.70
Mic0: NA     Mic1: U1
0: -----/--
1:*          -41.1dB/--
```

NOTE: New alkaline batteries should report 6 or more volts. The screen also shows the internal temperature of the recorder in degrees Celsius. This is intended for diagnostics and not to be an accurate measure of outside air temperature.

3.16 Temperature Sensor

The recorder includes an integrated temperature sensor to log temperatures inside the enclosure. This is intended for diagnostics only. Heat from the circuit and/or heat from sun on the enclosure can significantly increase the temperature reading above ambient air conditions.

3.17 The Backup Clock Battery

The backup clock battery for this device is not user-accessible. The clock battery is pre-installed in all new devices and should last up to eight (8) years with normal use. During normal operation the D cell batteries (or external power source when used) supplies power to the clock. The internal battery is only a backup to preserve the time settings if there is no main power or the SM3BAT is turned **OFF**. The unit will still operate properly with a dead clock battery; however, the clock will need to be reset if the D cells are removed or depleted.

3.18 How to Connect the GPS Time-Synch Option

Use the optional GPS time-synch receiver to calculate the location of wildlife signals from multiple SM3BAT units and multiple recordings. The optional GPS time-synch receiver synchronizes the SM3BAT clock to the GPS time base for extremely accurate time stamping on all your recordings. It also logs the path and location of the recorder when a recording was made. The GPS coordinates are logged in a file on the SD card and in metadata inside each recording file.

NOTE: The GPS receiver does not synchronize recordings when using recording triggers. You must record continuously to maintain synchronization.

Crystal oscillators used in clocks and electronics, including the SM3BAT, have frequencies that vary over time. The SM3BAT clock uses a temperature-compensated crystal with very low drift (< 3.5 ppm); however, clock drift of several milliseconds per hour can still occur.

The SM3BAT GPS receiver can synchronize your recordings across multiple recorders to within one millisecond. Arrange multiple time-synchronized recorders to triangulate a source location by measuring the relative time-of-arrival of sound waves as they travel.

NOTE: The GPS Time Synch Option provides synchronized recordings, but additional third-party tools are needed to determine the time of arrival of a particular signal to each microphone and calculate the position of the source.

1. Order an SM3BAT with this option or place a new order for the GPS time-synch receiver for the SM3BAT.
2. The **Location Settings** are automatically set by the GPS.

NOTE: Although the navigation steps are the same, the **Location Settings** coordinates are now read-only. You cannot change them. This change in location may affect the calculated sunrise and sunset times when using advanced scheduling commands.

3. To verify, perform the steps in 3.8 How to Set the Location and Time Zone.
4. Unpack the optional GPS time-synch receiver and the included 5-meter cable.
5. Remove the cap over the serial communication connector, the third connector from the top in the series of four ports in the connector module.
6. Attach, rotate, and secure the cable to the serial communication connector to make a weatherproof seal.
7. Position the receiver where a reliable GPS signal can be received.

NOTE: It can be difficult to acquire a GPS signal in thick vegetation.

8. The SM3BAT automatically detects the presence of the GPS receiver. When the recorder wakes up, the GPS receiver is powered up. A question mark (?) blinks between the date and time to indicate that the GPS receiver is attempting to acquire global positioning satellite data.

2014-Jan-31	?	09:00:00
SM3 99999	ULT	R1.0.0
A: 2/128	B: 0/128	
C: 0/128	D: 0/128	

9. When the GPS receiver has successfully acquired satellite transmission, the question mark changes to an exclamation point (!) and then a dollar sign (\$) indicating that the clock is now synchronized.
10. The SM3BAT clock automatically adjusts to GPS time.

3.18.1 Details of Operation

The SM3BAT wakes up 150 seconds before a scheduled recording to give the GPS time to acquire satellites. (Without the GPS option, the SM3BAT wakes up 30 seconds before a scheduled recording.) The recording starts within a fraction of a millisecond of GPS time. If the GPS has been used recently in the area, the position fix will take under a minute. If a significant amount of time has elapsed or the GPS has been shipped some distance, the GPS must download new tables. In this case the first position fix can take up to 40 minutes, but subsequent fixes should still occur in under a minute.

While making the recording, the SM3BAT automatically makes small adjustments by inserting or removing samples as needed to maintain synchronization with the GPS clock to within one millisecond. Additionally, if recording to a .wav file, the latitude and longitude coordinates are stored approximately every second. This data can then be viewed with Song Scope or extracted by Kaleidoscope software.

NOTE: The GPS receiver does not synchronize recordings when using triggered WAV mode. Synchronization is only provided for non-triggered WAV, non-triggered WAC, or triggered WAC.

If synchronization was acquired and maintained for the duration of the recording, the underscore character in the filename between the date and time changes to a dollar sign as shown in the following filename examples:

```
ARIZONA-1234_0+1_20160104_152209.wav
ARIZONA-1234_0+1_20160104$152209.wav
```

This is how you can tell if the entire recording was successfully synchronized. If the GPS signal was not successfully acquired before the recording started or was lost at any point during the recording for more than a few seconds, the \$ does not appear in the filename.

3.18.2 Extracting Location Information

If the recordings are in .wac file format, location information can be viewed in Song Scope (version 3.4 or later) by dragging the cursor around the spectrogram. If the recordings are in .wac or ZC mode and converted to .wav format in Kaleidoscope, the GPS data can be extracted into either a comma-separated values (.csv) file or Google .kml file. Select the **Extract GPS track** check box on the **GPS** tab and select your format. The resulting file shows waypoints for the end of each triggered event.

If you convert the recordings to zero crossing (ZC) format, the ZC file stores the GPS coordinates. You can view them in compatible zero crossing software. If you extract from .wac format, you can select a frequency in seconds to show path information.

You can also view the GPS locations per recording period and clock drift in the Summary file, generated by the SM3BAT while recording. The drift is logged as time delta from the SM3BAT real-time clock (RTC). Negative numbers means the RTC is slow relative to GPS while positive numbers mean the RTC is fast relative to GPS. This file can be used for special cases, where drift of unsynchronized recordings between two synchronized recordings can be estimated and corrected.

3.18.3 Power Considerations

The GPS receiver consumes about 500 mW of additional current. This can result in a reduction of about 65% of the estimated battery life for audio recordings and 50% of the estimated battery life for ultrasonic recordings.

4 Programs

4.1 Introduction

This section describes how to work with programs on the recorder using the LCD screen main menu and keypad.

The operating behavior of the SM3BAT is controlled by a program file. You can create and save multiple programs; however, you can only load one active program at a time on the recorder. You can load one of the built-in programs, import a program on an SD card, or create and edit your own program using the recorder or *SM3 Configurator* software. The program defines the recording schedule, commands, and all parameters. Out of the box, the SM3BAT does not have any program loaded and one must be loaded using one of the above methods.

4.2 Recording File Basics

Song Meter can record in mono using either channel 0 or channel 1, or in stereo using both channels. Bats can be recorded in full spectrum using standard .wav file format or compressed .wac file format. By default, compression is turned off and the audio files are stored as uncompressed .wav files. If you enable compression to reduce file size, the SM3BAT stores the audio files in the proprietary Wildlife Acoustics Audio Compression (WAC) file format with a .wac filename extension. On average, .wac files are 40% smaller than uncompressed .wav files though the superior noise filtering in triggered .wav mode can still result in lower file size.

NOTE: As memory card capacities expand and prices fall, the value of the compressed .wac file format decreases. Compression consumes more processing power. For most wildlife recording projects, we recommend .wav format.

In WAV mode, if either channel is recording, either because of a triggered recording or a continuous recording, the other channel will be forced to record as well. Therefore, it is not wise to record continuously (untriggered) on one channel and triggered on the other in WAV mode, as effectively the triggered side will also record continuously. If the desired behavior is to record continuously on one channel and only during a trigger on the other channel, then WAC mode will perform as desired.

The SM3BAT also offers a zero crossing format for recording bats.

4.3 How to Load a Built-In Program

You can load, edit, and run built-in programs directly on your recorder. The built-in programs are designed to implement the most popular recording schedules. Once loaded, the program will remain on the SM3BAT even without power. You also have the flexibility to edit one or more lines in the built-in programs to satisfy your specific objectives.

1. At the **Song Meter Main Menu**, select **Program**, and press **ENTER/MENU**.
2. Select **Load Program** and press **ENTER/MENU**.
3. On the **Select Program** screen, press **▲ Up** or **▼ Down** to select one of the following built-in programs:

```
Sunrise to Sunset
Sunset to Sunrise
Sunset - Sunrise ZC
Dawn for 3 hours
Dusk for 3 hours
30min on/30min off
24 hours
```

NOTE: For *sunset to sunrise* or *sunrise to sunset* programs, set the recorder location and time zone. See 3.8 How to Set the Location and Time Zone.

4. Press **ENTER/MENU**. The following message appears:

```
Program loaded
```

5. The program that you selected is loaded onto the recorder. Next, you can perform any of the following actions:
 - Edit the program.
 - Export the program to an SD card.
 - Start the program.

4.4 How to Edit a Program

Use this procedure to edit the currently active program directly on the recorder using the LCD screen and buttons. To learn more about each command and available settings, see 6.3 Program Commands.

1. At the **Song Meter Main Menu**, select **Program**, and press **ENTER/MENU**.
2. Load or import a program.
3. Select **Edit Program** and press **ENTER/MENU**.
4. Press **▼ Down** to select a line in the program.

5. To edit the line, press ► **Right** to advance to the command or value and then press ▲ **Up** or ▼ **Down** to make adjustments. When finished, press ◀ **Left** or **ENTER/MENU**.
6. To add or insert a line:
 - a. Press ▲ **Up** or ▼ **Down** to select the <Add/Insert> entry on the last line of the program and press **ENTER/MENU**. A new line appears at the bottom of the program.
 - b. Press ◀ **Left** and then press ▲ **Up** or ▼ **Down** to change the line number for the new line. Press **ENTER/MENU** to confirm the line number.
 - c. To edit the new line, press ► **Right** to advance to the command or value and press ▲ **Up** or ▼ **Down** to make adjustments. When finished editing, press ► **Right** or **ENTER/MENU**.
7. To delete a line:
 - a. Press ▲ **Up** or ▼ **Down** to select the line you want to delete.
 - b. Press ► **Right** to advance to the command for that line.
 - c. Press ▲ **Up** or ▼ **Down** until the <Delete> command appears.
 - d. Press **ENTER/MENU**. The line is removed and all higher lines cascade down in sequence by one line.
8. When finished editing all lines, press ◀ **Left**.
9. Any program errors appear. Repeat these steps to resolve the errors or press ◀ **Left** to ignore. Press ▼ **Down** to view the next problem. Press ▼ **Down** after the last problem to return to the **Program** menu. To return to the **Program** menu before reviewing all the problems, press ◀ **Left**.
10. When no errors exist, the following message appears:

```
Program edit OK
```

4.5 How to Create a Program On the Recorder

You can create a new program from scratch at line 1 using the recorder.

1. At the **Song Meter Main Menu**, select **Program**, and press **ENTER/MENU**.
2. Press ▼ **Down**, select **Edit Program**, and then press **ENTER/MENU**.
3. The following screen appears:

```
Edit Program
-01 <Add/Insert>
```

4. Press ► **Right** and then press ▲ **Up** or ▼ **Down** to cycle through the available program commands.
5. Select a command and press ► **Right**. Press ▲ **Up** or ▼ **Down** to adjust the associated parameters for the command.
6. Press ► **Right** to complete line 01 and repeat these steps for line 02 and each subsequent line.

7. When finished, press ◀ **Left** to check the program. Any program errors or warnings appear. Press ▼ **Down** to cycle through multiple errors or warnings.
8. Press ◀ **Left** to exit.
9. Edit the program to resolve any errors.

4.6 How to Export a Program

You can export the current program to an SD card in slot A.

1. At the **Song Meter Main Menu**, select **Program**, and press **ENTER/MENU**.
2. Press ▼ **Down** to select **Export Program** and press **ENTER/MENU**. The following message appears:

Program exported

3. Eject the SD card in slot A and examine the top-level folder contents on a computer or laptop. The exported file name is always the recorder prefix with the .PGM extension. For example:

SM3001234.PGM

The default prefix is the device serial number. You can specify a new prefix on the recorder or in a custom program.

NOTE: If a file with that name already exists on the SD card, it is overwritten.

4.7 How to Import a Program

Use this procedure after saving a custom program to the root or top-level directory of an SD card from another recorder or from the SM3 Configurator. You can import a program file (.PGM) from the SD card in slot A.

1. At the **Song Meter Main Menu**, select **Program**, and press **ENTER/MENU**.
2. Select **Import Program** and press **ENTER/MENU**.
3. At the **Select program file** prompt, press ▲ **Up** or ▼ **Down** to select a program file on the memory card in slot A.
4. Press **ENTER/MENU**.
5. If no warnings or errors exist, the following message appears:

```
Program imported
```

6. If a warning or error exists, the line number and a short notification appear as shown in the following example:

```
Program error
Line 14
No GAIN cmd
```

- a. Press **◀ Left** to return to the list of available programs and choose a different one.
- b. Press **◀ Left** again to exit and go back to the **Program** menu. Edit the program using the recorder or *SM3 Configurator* software and try the import again. Select **Import Program** when the program is error-free.
7. The program that you select is imported onto the recorder and loaded as the active program. Press **◀ Left** to return to the **Program** menu.
8. You can perform any of the following actions on the imported active program:
 - Edit the program.
 - Export the program to an SD card.
 - Start the program.

4.8 How to Start a Program

Follow these steps to start the current program. The current program is the last one you loaded or imported.

1. Press **PROGRAM START**.
2. Errors or warnings may appear. For example:

```
Program warning
Line 12
No microphones
```

3. Press **▼ Down** to advance to the next error or warning, if any.
4. If you do not press any buttons for 60 seconds, the Program Checker exits.
 - a. If there is at least one *error*, go back to the main menu. Edit the program and fix the errors.
 - b. If there are only *warnings*, the program starts running. Editing the program or attaching a missing item such as a microphone are optional steps that can often be used to resolve any *warnings*.
5. Press **PROGRAM START** again to run the revised program.
6. If the scheduled start time is more than one minute into the future (three minutes if using the GPS option), the recorder enters sleep mode to conserve power. The SM3BAT wakes up 30 seconds before the scheduled recording start time. The device automatically wakes 2 minutes early when

the GPS time-synch receiver option is detected and wakes 3 minutes early when hydrophones are installed.

NOTE: If you use an AT TIME, AT SRIS or AT SSSET command that is within a daily repeating loop, and start the program after that time of day, the recorder will assume you wish to record starting at the previously occurring sunset, sunrise or time, and begin recording immediately.

For example, if you have a program that starts with AT TIME 16:00:00 and records for 3 hours, but you start the program at 17:00:00, the recorder will not wait until 16:00:00 the next day, but instead will start recording immediately and record the remaining two hours of the days' schedule.

If you start a program with an AT TIME command that is not contained in a daily loop or the program starts with an AT DATE command, then the recorder will wait until the next specified time or date.

4.9 How to Stop a Program

Press and hold the **PROGRAM STOP** button while a program is running or scheduled to run to stop it from continuing. You may have to hold the button for several seconds. If you stop a running program, the recorded output up until recording was stopped is saved.

5 SM3 Configurator Software

5.1 Introduction

Use the *SM3 Configurator* software to create and edit recording programs for any SM3 series recorder. The software is available for Microsoft Windows, Apple Mac OSX, and Red Hat Linux.

You can also use this application to perform the following tasks:

- Estimate battery life and memory capacity for recording deployments.
- Open a recording to view the commands and settings used in the original program that captured it.
- Edit and save your own versions of a program and use them on future deployments to one or more SM3 acoustic or ultrasonic recorders.

5.2 How to Install the SM3 Configurator

Follow these steps to download and install the SM3 Configurator software.

1. Navigate to www.wildlifeacoustics.com/support/download-software.
2. Find the setup file appropriate for your operating system.
3. Download the file and follow the installation instructions.

5.3 How to Open the SM3 Configurator

On Microsoft Windows computers, the program is located in the **Wildlife Acoustics** folder in **Program Files**. The installer creates shortcuts on your desktop and in the **Start** menu. On Apple Mac OSX computers, the program should be moved to the **Applications** folder.

5.4 SM3 Configurator User Interface

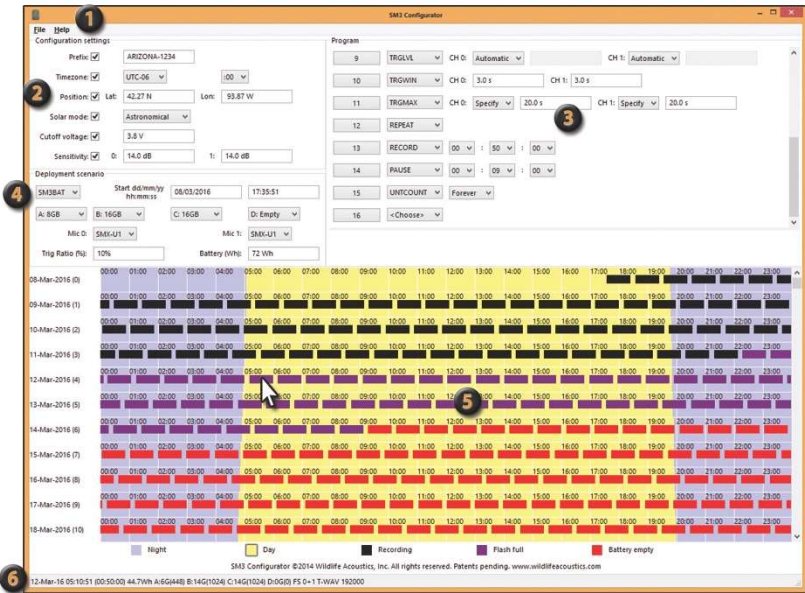

SM3 Configurator Software

- 1 **File and Help Menus:** Click the **File** menu to load a sample program, open one of your own programs, save a program, or exit. Click the **Help** menu and choose **About** to view the currently installed version number of the utility.
- 2 **Configuration Settings:** Adjust the settings in this section to override the settings on the recorder that receives your imported program.
- 3 **Program:** Enter your choice of commands and adjust their parameters to create, edit, and save your own custom programs.
- 4 **Deployment Scenario:** Gauge the impact of your deployment settings on battery power, memory capacity, and the recording schedule.
- 5 **Scrollable Calendar View:** Use this section to explore the recording schedule, estimated battery life, and memory card requirements of your program. Black bars represent successful recordings; purple bars require more memory; and red bars represent insufficient power. Blue and yellow shading indicates night and day based on program settings.
- 6 **Status Bar:** When you position your mouse pointer over an entry in the schedule, the status bar displays details about that point in the program. From left to right, it shows the recording date, time, duration, power consumption, memory card utilization, the running total number of sound files, recording type, channels, file format, and sample rate.

5.5 How to Create a Program (SM3 Configurator)

Although you can create a new program starting at line one, as a time-saving best practice use this procedure to create a new program from one of the sample programs provided as a template.

1. Open the **SM3 Configurator** software application.
2. Click the **File** menu and choose one of the sample programs:
 - Sunrise to Sunset
 - Sunset to Sunrise
 - Sunset - Sunrise ZC (SM3BAT models only)
 - Dawn for 3 hours
 - Dusk for 3 hours
 - 30min on/30min off
 - 24 hours
3. In the **Program** section, examine each line of the program. Use the drop-down value lists to edit fields. You can use the mouse or press the **Tab** key to advance to the next field. Press **Shift+Tab** to go back to the previous field. Press the arrow keys on your keyboard to cycle through value lists.
4. To change a command in any line, select another command from the list.
5. The last line in a program is empty and shows **<Choose>** in its command field ready for you to add a new line. To insert a new line, click a line number.
6. To remove a line, select **<Delete>** in the command field.
7. (Optional) Adjust the **Configuration Settings** section to override the settings in the recorder.
8. (Optional) Adjust the **Deployment Scenario** section to estimate a recording schedule.
9. Resolve any errors that appear below the **Program** section.
10. Click the **File** menu and choose **Save**.
 - a. Save the program to your computer to continue editing it or to use it as a template for future programs.
 - b. Save the program to an SD card to import it onto one or more recorders in the field.

5.6 How to Adjust Configuration Settings

Select any of the check boxes in the **Configuration Settings** section to override any values already set on an individual SM3BAT unit when you import your program. For example, select the **Prefix** check box and enter a new prefix for a location or project name.

All of the settings in this section are documented elsewhere in this guide.

5.7 How to Adjust Deployment Scenario Settings

Use the fields in the **Deployment Scenario** section to estimate the recording schedule for the currently open program in the calendar view.

1. Load a sample program or a custom program.
2. In the **Deployment Scenario** section, choose the target Song Meter device for this program:
 - **SM3**: This model has two built-in internal microphones.
 - **SM3BAT**: This model supports ultrasonic sample rates and zero crossing recording. It does not have built-in acoustic microphones.
3. In the **Start** fields enter the date and time in the following format:
DD/MM/YYYY HH:MM:SS
4. In the series of four (4) fields labeled **A**, **B**, **C**, and **D**, select the estimated capacity of the memory card you plan to insert in each slot.
5. In the **Mic 0** field, select the type of microphone you plan to use on the channel 0 (left). For mono, specify just one microphone. If you do not select a microphone, errors will be shown in the program. Selecting the proper microphone also makes the battery longevity estimate more accurate as the external microphones do use more power.
6. In the **Mic 1** field, select the microphone you plan to use on channel 1 (right).
7. In the **Trig Ratio (%)** field, indicate the percentage of time during recording periods that a given microphone will be triggered. This only applies to triggered recordings. The default value of 10% is a good estimate for bat recordings. Adjust as needed based on past experience with your specific recording conditions.
8. In the **Power (Wh)** field, enter the anticipated battery energy to be used for recordings made from this program in watt-hours. Wh can be calculated by multiplying the battery capacity in amp hours (divide by 1000 if given in milliamp hours) by the total voltage of the batteries. Total voltage is the sum of all the battery cells. For example, 4 internal alkaline D size batteries at 1.5 V each with a capacity of 12,000 milliamp hours would be 12,000 divided by 1,000 = 12 amp hours. And 1.5 V times 4 batteries = 6 V. Multiplying 6 V times 12 amp hours gives us 72 Wh.

NOTE: Using a 12V external battery is about 85% efficient as compared to 6V. Multiply your calculated watt-hours by 0.85 before entering into the configurator to appropriately derate the power for more accurate longevity calculations.

9. Examine the recording calendar and make any adjustments.
10. Click the **File** menu and choose **Save**. Save the resulting .PGM file to a memory card and insert in slot A of the SM3BAT recorder.
11. Import the program onto the recorder. See 4.7 How to Import a Program on page 28.

5.8 How to Use the Scrollable Calendar View

The scrollable view on the lower portion of the application window shows the recording schedule for over a year from the **Start** date and time in the **Deployment Scenario** section. Recording periods are shown with black bars. Blue shaded areas represent nighttime and yellow shaded areas represent daytime based on sunrise/sunset calculations determined by the time zone (hours relative to UTC), latitude, and longitude specified in the **Configuration Settings** section. The recorder breaks up long recordings so they do not exceed the 2.0 GB limit.

The scrollable view also illustrates when Song Meter is likely to stop recording after running out of memory storage or battery power. Running out of memory storage is shown with recordings in purple, and running out of power is shown with recordings in red. These are estimates based on the memory card and battery capacity specified in the **Deployment Scenario** section. Actual performance is subject to variations in memory card and battery manufacturers and numerous other factors such as temperature or battery charging method.

To estimate memory requirements for triggered recordings, set the **Trig Ratio (%)** field in the **Deployment Scenario** section. The application estimates memory consumption based on how often the unit is likely to be triggered as opposed to merely waiting in **nap** mode to record. The default value of 10% is good for bat recording. You can adjust based on personal experience with your specific recording conditions.

6 Developing Custom Programs

TIP: Start by loading one of the sample programs and then make adjustments to create your own custom programs.

6.1 Loops

An essential logical structure in any computer program, a *loop* repeats a task, state, or condition until a necessary event occurs. For example, you need a program that waits, and continues to wait until sunset; and then you want it to record, and repeat that action, recording over and over (we call that a *loop*) until 15 minutes before sunrise.

Loops are programmed by using pairs of **REPEAT** and **UNT** commands, nested to any depth. Loops have an explicit ending condition, such as a date for an **UNTDAT** command or a count for an **UNTCOUNT** command. In addition, loops have an implicit ending time, inherited from any enclosing loops. The implicit ending time is the earliest of all the enclosing loop ending times. In other words, the ending condition of a loop is either its own ending condition or the implicit ending time, whichever occurs first.

The **RECORD** command likewise inherits an implicit ending time from any enclosing loops, perhaps causing a **RECORD** command to finish earlier than indicated by its own duration .

UNTCOUNT loops do not have an ending time of their own, although they do pass along any implicit ending time that they inherit. If a program contains just one loop, a **REPEAT/UNTCOUNT** loop, with a **RECORD** command inside that loop, then the **RECORD** command will always run for its full duration, and the loop will end after the specified count of iterations.

6.2 AUTO Values

Instead of an explicit value, some commands allow a value of **AUTO** for one or more of their parameters. Examples include the channel 0 and 1 parameters of the **GAIN** command and the **FS** command channels and rates. When **AUTO** values are set, the recorder automatically chooses appropriate values based on its current configuration. For example, **AUTO** settings tell the recorder to use the external SMM-A1 microphone if it is attached rather than the built in microphone.

All the built-in sample programs use **AUTO** values to help you get started. The **AUTO** behavior of each command is specified in the relevant section below.

6.3 Program Commands

Use the following commands to create programs for your specific recording needs. A program can contain up to 99 command lines.

NOTE: Some commands listed in this section refer to *sunrise* or *sunset* in a general sense and depend on them in program calculations. The recorder recognizes different methods for calculating precise sunrise and sunset times. To specify a method and view the next available sunrise and sunset times, select **Sunrise/Sunset Type** in the **Settings** menu.

HPF {OFF,220HZ,1KHZ,16KHZ} {OFF,200HZ,1KHZ,16KHZ}

This sets the channel 0 and 1 analog high pass filter. A high pass filter only allows signals higher than the specified frequency to be recorded. For recording very low frequency sounds such as elephants, set this to **OFF**. Otherwise it is useful to cut down on wind and anthropogenic noise and should be set to at least 220 Hz. If your signals of interest are higher, it is better to go even higher.

The filter is a two-pole filter when set to 220 Hz or 1 kHz, meaning it attenuates sounds at 12dB per octave. So if set to 1.0 kHz, a 500 Hz sound would be attenuated by 12dB. Every 6dB represents a halving of sound level, so the 500 Hz sound would appear in the recording at one-fourth (.250) of its original amplitude.

For bats, the SMM-U1 microphone has a built-in 4-pole filter at 8 kHz. If you expect bats vocalizing below 16 kHz, set this HPF to 1 kHz and the 8 kHz filter in the microphone will reduce acoustic sound below 8 kHz. If you do not expect bats below 16 kHz, it is best to use set this filter to 16 kHz and filter out more acoustic noises that might cause non-bat recordings to occur. At 16 kHz setting the filter is a four-pole filter.

GAIN <gain-channel-0> <gain-channel-1>

Analog voltage gain settings. The range is 0 dB to 59.5 dB in 0.5 dB steps for acoustic sample rates (96 kHz or below) or 0 dB or 12 dB for ultrasonic recordings. Gain has **Auto** selection available.

For bats, we recommend 12 dB unless the bats are very close in which case 0 dB might work better.

Gain **AUTO** setting behavior:

- Internal or external acoustic microphone on the channel
 - Acoustic Sample Rate (96kHz or below): 24 dB
 - Ultrasonic Sample Rate (192kHz or above): 0 dB
- External hydrophone on the channel: 0 dB
- Ultrasonic microphone on the channel: 12 dB

TIP: If your recordings are too loud or distorted, try decreasing the **GAIN** value.

FS <WAV,WAC> {OFF,0,1,0+1} <sample rate>

Specifies the file type produced, the source channels used, and the sample rate for full-spectrum recordings. Channel and sample rate both have **AUTO** selections available.

Choose the standard .wav format for recording bats. It consumes less power and can be opened in any audio software. The .wac file format offers about a 40% reduction in storage, but at the expense of 40% more power consumption. Choose WAC for acoustic recordings when storage is more important than power.

The following sample rates are available on two channels simultaneously unless otherwise specified:

- 1000
- 2000
- 4000
- 8000
- 9600
- 12000
- 16000
- 19200
- 24000
- 32000
- 48000
- 96000
- 192000
- 256000 (1 channel in WAC mode, up to 2 channels in WAV mode)
- 384000 (one channel)

Choose a sample rate that is at least double the highest frequency to be recorded.

The **AUTO** setting behavior can be seen in the following chart. A sample rate in the chart indicates that channel will be recorded at that sample rate (in kHz), a OFF indicates that channel will not be recorded.

- If WAC is selected:

Channel 0 Mic	Channel 1 Mic	Channel 0 Rate	Channel 1 Rate
None	None	192k	192k
None	A1	OFF	24k
None	U1	OFF	192k
A1	None	24k	OFF
A1	A1	24k	24k
A1	U1	192k	192k
U1	None	192k	OFF
U1	A1	192k	192k
U1	U1	192k	192k

- If WAV is selected:

Channel 0 Mic	Channel 1 Mic	Channel 0 Rate	Channel 1 Rate
None	None	256k	256k
None	A1	OFF	24k
None	U1	OFF	256k
A1	None	24k	OFF
A1	A1	24k	24k
A1	U1	256k	256k
U1	None	256k	OFF
U1	A1	256k	256k
U1	U1	256k	256k

ZC {OFF,0,1,0+1} {4,8,16}

Specifies the source channels used and the division ratio for zero-crossing recordings. **AUTO** settings are available.

Zero Crossing is not the same as full-spectrum recording. In full spectrum recording, the SM3BAT samples audio signals at a specified sample rate. In

contrast, zero crossing mode measures the time between transitions of the signal between positive and negative values relative to some sensitivity threshold. Zero crossing has advantages including significantly lower power consumption and memory card storage requirements. However, zero crossing representations of bat calls lack information about the changing amplitude and harmonic structure of the underlying signal. It is possible to convert from full spectrum to zero crossing by removing information from the signal, but it is not possible to convert from zero crossing back to full spectrum.

During the scheduled recording period, SM3BAT will create zero crossing sequence files for each trigger. The SM3BAT assesses each sequence to verify that it is a bat pass and not a non-bat trigger. The resultant files can be opened directly and analyzed with Wildlife Acoustics' Kaleidoscope software or third party zero-crossing software.

The length of file is defined by length of activity and **TRGWIN** setting or a maximum length of 15 seconds.

Channel **AUTO** setting behavior:

- One SMM-U1 ultrasonic microphone on channel 0: 0
- One SMM-U1 ultrasonic microphone on channel 1: 1
- Two SMM-U1 ultrasonic microphones: 0+1
- No attached SMM-U1 ultrasonic microphones: OFF

FRQMIN <freq-channel-0> <freq-channel-1>

Specifies the lower bound for the frequencies of interest to the scrubber and the triggering mechanism. Values are 1 kHz – 192 kHz in 1-kHz steps, or **OFF**

Echolocations or other signals occurring below this frequency will not cause a trigger and will be consider noise to the scrubber mechanism. A setting of 16kHz works well for most bat applications but it may be necessary to set lower if lower frequency species are to be recorded.

This command is only relevant if **TRGLVL** is not **OFF**.

See **DMIN** for more information on how the scrubber uses this value.

See **TRGLVL** for more information on how the trigger uses this value.

FRQMAX <freq-channel-0> <freq-channel-1>

Specifies the upper bound for the frequencies of interest to the scrubber and the triggering mechanism. Values are 1 kHz – 192 kHz in 1-kHz steps, or **OFF**.

Echolocation or other signals occurring above this frequency do not cause a trigger and are considered noise to the scrubber mechanism. 192kHz is recommended for recording bats.

This command is only relevant if **TRGLVL** is not **OFF**.

See **DMIN** for more information on how the scrubber uses this value.

See **TRGLVL** for more information on how the trigger uses this value.

DMIN <dur-channel-0> <dur-channel-1>

Specifies the minimum duration for a signal in the specified frequency range to be a valid signal to satisfy the scrubber. Values are 0.1 – 800.0 msec in 0.1-msec steps, or **OFF**.

The scrubber automatically deletes files where no suitable bat echolocation is detected. The scrubber looks for at least two narrow band signals of at least this **DMIN** duration and shorter than **DMAX** and within the frequency range specified by **FRQMIN** and **FRQMAX**. If two such signals exist, the file is saved, if they are not, the file is not saved. 1.5ms is recommended for recording bats.

If **TRGLVL** is not **OFF**, the files are scrubbed based on this field and **DMAX**. If you do not want to scrub files, set this command and **DMAX** to **OFF**.

DMAX <dur-channel-0> <dur-channel-1>

Specifies the maximum duration for a signal in the specified frequency range to be a valid signal to satisfy the scrubber. Values are 0.1 msec – 800.0 msec in 0.1-msec steps, or **OFF**. **OFF** is recommended for recording bats.

The shortest **DMAX** chosen between channel 0 and 1 will also truncate the total length of a WAV while recording on stereo channels. This means that if one channel is in mid trigger and has not yet reached its **DMAX** and the other channel does reach **DMAX**, the first channel will be truncated shorter than its programmed **DMAX**.

See **DMIN** for more information on how the scrubber uses this value.

TRGLVL <level-channel-0> <level-channel-1>

Specifies the digital trigger level. Thresholds are either absolute (negative values) or relative to the measured noise floor (positive values). The range is -88 dB – +88 dB in 1-dB steps or **OFF** or **AUTO** selection is available.

If either channel value is not **OFF**, then the **FRQMIN**, **FRQMAX**, **DMIN**, **DMAX**, **TRGWIN**, and **TRGMAX** commands are required before the next **RECORD** command.

The trigger is satisfied if a signal exceeds the specified level within the frequency range defined by **FRQMIN** and **FRQMAX**.

Turning on triggers will also activate file scrubbing. For information on scrubber function and how to turn off the feature, see **DMIN**.

Relative triggers (positive level values) are strongly recommended for recording bats as the trigger will intelligently adapt to the environment.

If WAV file format is specified in the FS command, an individual time-stamped WAV file will be created for each triggered event during the scheduled recording period. If WAC compressed file format is specified, there will be one file created for the recording duration containing all the triggered events.

Trigger **AUTO** setting behavior:

- At least one SMM-U1 ultrasonic microphone on either channel: +12 dB
- No SMM-U1 ultrasonic microphones attached: OFF

NOTE: Triggers do not work well for most acoustic applications, but this command must be used to prevent an error. **Off** or **Auto** should be selected (**Auto** will select **Off** as well). This is to maintain cross compatibility of programs from SM3 to SM3BAT.

TRGWIN <window-channel-0> <window-channel-1>

Specifies the maximum recording duration in the absence of a triggering signal. Values are 0.1 sec – 9.9 sec in 0.1-sec steps.

This command is only relevant if **TRGLVL** is not **OFF**.

This should be set sufficiently long to avoid a recording ending after one echolocation. If a bat echolocates every 0.5 seconds and this was set to 0.1 seconds, you would get a new trigger with every single echolocation. Three (3.0) seconds works well for species in most parts of the world. Some standards describe a *bat pass* by specific recording trigger window. Use this command with **TRGMAX** to constrain recordings to a specific duration.

TRGMAX <len-channel-0> <len-channel-1>

Specifies the maximum duration for a triggered recording. Values are 0.1 sec – 99.9 sec in 0.1-sec steps, or **OFF**. Some software programs only accept files under certain durations. Use this command to set a maximum file duration.

In ZC mode, the maximum file size is 15 seconds even if this command is set higher.

This command is only relevant if **TRGLVL** is not **OFF**.

NAP <delay>

Specifies how long to wait in the absence of a trigger before going into power-saving nap mode. Set a value from 1 to 99 minutes in 1 minute

steps, or set to **OFF**. It takes approximately 200 ms to wake from a nap to start recording. Once out of a nap, the SM3 remains ready and waits for a trigger for the amount of time specified here. Shorter times yield greater battery savings with the compromise that you often lose the first 200 ms of a recording.

RECORD hh:mm:ss

Starts a new recording of the specified duration. If the **RECORD** command is inside a repeat/until loop, the recording may end early to match the outer loop ending time.

Before a **RECORD** command, your program must include one of each of the following commands: **HPF, GAIN, FS, ZC, and TRGLVL**. It is not necessary to repeat those commands before each **RECORD** command, but you may if you wish to have different values in effect at each **RECORD** command. In addition, at least one of the **FS** or **ZC** commands must have its **channels** parameter set to a value other than **OFF**.

Recording files larger than 2.0 GB are divided into smaller segments.

PAUSE hh:mm:ss

Pauses the program for the specified amount of time. If you set the duration of the **PAUSE** command to greater than 1 minute (3 minutes if using the GPS option), the SM3BAT enters low-power sleep mode and wakes up at the next scheduled recording.

AT DATE DDMMYY

Causes the program to wait until the specified date. YY are the last two digits of the year in the current century beginning with the year 2000. Always put the AT DATE command as the first command in your program.

NOTE: If you start the program after the specified **AT DATE**, the command is ignored and the program continues.

AT TIME hh:mm:ss

Causes the program to wait until the specified date time.

NOTE: If you use an AT TIME, AT SRIS or AT SSET command that is within a daily repeating loop, and start the program after that time of day, the recorder will assume you wish to record starting at the previously occurring sunset, sunrise or time, and begin recording immediately.

For example, if you have a program that starts with AT TIME 16:00:00 and records for 3 hours, but you start the program at 17:00:00, the recorder will not wait until 16:00:00 the next day, but instead will start recording immediately and record the remaining two hours of the days' schedule.

If you start a program with an AT TIME command that is not contained in a daily loop or the program starts with an AT DATE command, then the recorder will wait until the next specified time or date.

AT SRIS±hh:mm:ss

Causes the program to wait until sunrise, plus or minus the specified time.

AT SSET±hh:mm:ss

Causes the program to wait until sunset, plus or minus the specified time.

REPEAT

Indicates the beginning of a loop. Must be ended by an **UNT** command.

UNTDAT DDMMYY

Ends a loop when the specified termination date is reached. Any **RECORD** commands in progress in this loop are forced to stop recording.

UNTTIME hh:mm:ss

Ends a loop when the specified termination time is reached. Any **RECORD** commands in progress in this loop are forced to stop recording.

UNTSRIS±hh:mm:ss

Ends a loop at sunrise, plus or minus the specified time. Any **RECORD** commands in progress in this loop are forced to stop recording.

NOTE: Some commands listed in this section refer to *sunrise* or *sunset* in a general sense and depend on them in program calculations. The recorder recognizes different methods for calculating precise sunrise and sunset times. To specify a method and view the next available sunrise and sunset times, select **Sunrise/Sunset Type** in the **Settings** menu.

UNTSSET±hh:mm:ss

Ends a loop at sunset, plus or minus the specified time. Any **RECORD** commands in progress in this loop are forced to stop recording.

UNTCOUNT {<count>, INF}

Ends a loop after <count> iterations. **INF** specifies an infinite count.

FEATURE <feature number> {OFF,ON}

This is for advanced use only and is not a required command by the program checker. The first parameter is a number from 1 to 16 and the second parameter is OFF or ON. By default, all features are OFF.

- FEATURE #01: If ON, disables the LED blinking during recording. Insert into the top of a program "01 FEATURE 01 ON" to disable the LEDs.
- FEATURE #02: If ON, enables 32-bit recording mode. 32-bit mode is only enacted with very specific program settings and is intended for use only with SM3M Marine recorders.

This command may be used to add additional features in the future.

PLAY {0-9}

Not applicable to SM3BAT.

6.4 How to Work With the Program Checker

The Program Checker runs automatically to verify the configuration of the hardware and software, and to check your program for errors or warning conditions. If it detects contradictory commands, the Program Checker reports the latter of the two as the error source. Use the Program Checker output to correct your program, save it, and then attempt to import or run it again.

1. The Program Checker runs at all of the following times:
 - After you finish loading or importing a program.
 - After you finish editing a program and press the main buttons on the device to exit the editor as viewed through the LCD screen.
 - Before you run a program by pressing the **PROGRAM START** button.
2. The Program Checker performs several tests on the current program. For example, it checks for the following items:
 - Balanced **REPEAT/UNTX** loops
 - At least one **RECORD** command that is reachable; in other words at least one **RECORD** precedes, or is inside of, an infinite loop.
 - All required parameters set prior to a **RECORD** command.
 - Parameters that are consistent with the present hardware.
3. It shows *errors* (if any), followed by *warnings* (if any). It shows the matching line number in your program for the error or warning.
4. To view the next error or warning, press the ▼ **Down** button.
5. To exit the Program Checker, press the ◀ **Left** button. You can also exit by pressing ▼ **Down** after the last error or warning.

6. If no buttons are pressed for 60 seconds while a problem is displayed, the Program Checker times out and exits.
7. When the Program Checker exits:
 - If you were loading or editing a program, you return to the main menu.
 - If you were running a program and there are no errors (only warnings or no problems at all), your program starts.

6.5 How to Resolve Program Checker Errors

When a program contains *warnings*, you can address them or ignore them and continue, the program will run with *warnings*. However, when a program contains one or more *errors*, it will not run. To resolve an error, edit the program and adjust a parameter or add, move, or delete a command line. Refer to the following list of the most common possible program warnings and errors.

SM3BAT Program Errors and Warnings

Message	Warning/Error	Explanation
Unmatched REPEAT:	error	a REPEAT command for which no corresponding subsequent UNT_X command can be found.
Unmatched UNTX:	error	an UNT_X command for which no corresponding preceding REPEAT command can be found.
Inf lp bfr REC/PLAY:	error	the program has an infinite loop before reaching any RECORD or PLAY command.
Unreachable command:	warning	the program has commands following an infinite loop.
No RECORD or PLAY:	error	the program contains neither a RECORD nor a PLAY command.
No HPF cmd:	error	a RECORD command has been reached with no preceding HPF command.
No GAIN cmd:	error	a RECORD command has been reached with no preceding GAIN command.
No FS cmd:	error	a RECORD command has been reached with no preceding FS command.
No ZC cmd:	error	a RECORD command has been reached with no preceding ZC command.
No DTRGLVL cmd:	error	a RECORD command has been reached with no preceding DTRGLVL command.
No FREQMIN cmd:	error	a RECORD command has been reached, with triggered recording enabled, with no preceding FREQMIN command.
No FREQMAX cmd:	error	a RECORD command has been reached, with triggered recording enabled, with no preceding FREQMAX command.
No DURMIN cmd:	error	a RECORD command has been reached, with triggered recording enabled, with no preceding DURMIN command.

Message	Warning/Error	Explanation
No DURMAX cmd:	error	a RECORD command has been reached, with triggered recording enabled, with no preceding DURMAX command
No DTRGWINDOW cmd:	error	a RECORD command has been reached, with triggered recording enabled, with no preceding DTRGWINDOW command
No DTRGMAXLEN cmd:	error	a RECORD command has been reached, with triggered recording enabled, with no preceding DTRGMAXLEN command
FREQMAX <= FREQMIN:	error	a RECORD command has been reached, and a channel's preceding FREQMAX value is less than or equal to its preceding FREQMIN value.
DURMAX <= DURMIN:	error	a RECORD command has been reached, and a channel's preceding DURMAX value is less than or equal to its preceding DURMIN value.
Nap not triggered:	warning	a NAP command has been reached with triggered recording disabled.
Bad FS sample rate:	error	a RECORD command has been reached and the preceding FS command's rate parameter does not have one of the allowed values: OFF, AUTO, 1000, 2000, 4000, 8000, 9600, 12000, 16000, 19200, 24000, 32000, 48000, 96000, 192K, 256K, 384K
No record channels:	error	a RECORD command has been reached and the preceding FS and ZC commands' channel parameters are all OFF.
ZC not triggered:	error	a RECORD command has been reached, the preceding ZC command's channel parameter is not OFF, and triggered recording is not enabled.
Ult rate, no ult hw:	error	a RECORD command has been reached, the preceding FS command's channel parameter is not OFF, and its rate parameter is greater than or equal to 192K.
Using only channel 0:	run-time warning	a RECORD command has been reached, an ultrasonic board is present, the preceding FS command's channel parameter is AUTO, there are two external microphones, and the preceding FS command's rate parameter is set too high for stereo for the command's file type (WAV, WAC): the recorder will choose one channel to use rather than stereo, choosing whichever channel has an ultrasonic microphone or channel 0 if they both have ultrasonic microphones.
Using only channel 1:	run-time warning	a RECORD command has been reached, an ultrasonic board is present, the preceding FS command's channel parameter is AUTO, there are two external microphones, and the preceding FS command's rate parameter is set too high for stereo for the command's file type (WAV, WAC): the recorder will choose one channel to use rather than stereo, choosing whichever channel has an ultrasonic microphone or channel 1 if they both have ultrasonic microphones.
Bad rate for stereo:	error	a RECORD command has been reached and the preceding FS command's channel parameter is 0+1 (stereo) and its

Message	Warning/Error	Explanation
		rate parameter is set too high for its file type (WAV, WAC).
No microphones:	run-time error	a RECORD command has been reached, an ultrasonic board is present, and there are no external microphones attached.
Missing microphone:	run-time warning	a RECORD command has been reached, an ultrasonic board is present, and there is no external microphone on a channel explicitly selected (0, 1, or 0+1; not AUTO or OFF) in the preceding FS or ZC command.
No ultra microphones:	run-time warning	a RECORD command has been reached, the preceding FS command's channel parameter is not OFF, its rate parameter is 192k or greater, and only external acoustic microphones are connected.
Acous rate ultr mics:	run-time warning	a RECORD command has been reached, the preceding FS command's channel parameter is not OFF, its rate parameter is less than 96000, and only ultrasonic microphones are connected.
HPF 16K, no ult hw:	error	a RECORD command has been reached, an ultrasonic board is not present, and the preceding HPF command has one or both channels set to 16K.
HPF 16K, acoust rate:	error	a RECORD command has been reached, the preceding FS command rate parameter is less than 192k, and the preceding HPF command has one or both channels set to 16K.
Bad ZC gain:	error	a RECORD command has been reached, an ultrasonic board is present, the preceding ZC command has a channel enabled (either explicitly at any time or via AUTO selection at run time), and the preceding GAIN command value for that channel is neither 0 nor 12 dB.
Bad FS ultra gain:	error	a RECORD command has been reached, an ultrasonic board is present, the preceding FS command has a channel enabled (either explicitly at any time or via AUTO selection at run time) and a rate greater than 96000, and the preceding GAIN command value for that channel is neither 0 nor 12 dB.
ZC, no ult hw:	error	a RECORD command has been reached, an ultrasonic SM3BAT recorder is not present, and the preceding ZC command Channel parameter is not OFF.
ZC acoust mic no FS:	run-time warning	a RECORD command has been reached, an ultrasonic board is present, the preceding ZC command has a channel enabled (either explicitly or via AUTO selection) and the preceding FS command does not have that same channel enabled (either explicitly or via AUTO selection), and an external acoustic microphone is attached to that channel.
Ultra mic no ultr hw:	run-time warning	a RECORD command has been reached, an ultrasonic device is not present, the preceding FS command Channel parameter is not OFF and its rate parameter is

Message	Warning/Error	Explanation
		AUTO, and at least one external ultrasonic microphone is connected.
Ext acst & ultr mics:	run-time warning	a RECORD command has been reached, the preceding FS command Channel parameter is not OFF and its rate parameter is AUTO, and an external ultrasonic microphone is connected to one channel and an external acoustic microphone is connected to the other channel.
Can't open play file:	run-time error	a PLAY command has been reached and there is a failure accessing the SD card in slot A or a failure opening the desired file on the card.

7 Managing Deployments

Recording time is determined by the demands of your program and the available power and memory resources required to carry out the recordings. The SM3BAT can only record while it has sufficient power available in the batteries and room to save recordings on SD memory cards. Download our free *SM3 Configurator* software application to see detailed visual forecasts for remaining battery life and memory card utilization given your specific recording schedule and configuration.

7.1 How to Estimate Battery Life

In sleep mode between scheduled recordings, the SM3BAT uses almost no power (around 0.5 mW) so it can remain idle (not recording) for months at a time. However, the batteries will discharge on their own over time. When recording, depending on accessories, sample rates, compression, and other variables, the SM3BAT can use as little as 500 mW power. That translates to up to 2 weeks of nightly recording using high-quality alkaline batteries. Use the *SM3 Configurator* to estimate a recording schedule based on your program requirements.

7.2 How to Estimate Memory Requirements

7.2.1 Ultrasonic Recording

In a typical night with bat activity (and no rain or gusty wind), you need about 0.5 GB for a stereo recording. Even with gusty wind causing false triggers, you only need about 2.0 GB per night. In WAV mode, since files are scrubbed for non-bat recordings, you need even less. A 32 GB card can last for 2-8 weeks. In zero crossing mode, you can expect a 32 GB card to last for months if not years.

7.2.2 Acoustic Recording

Acoustic recordings without triggers consume 2 bytes (16-bits) per sample, times the sample rate, times the number of channels per second. For example, a recording made at a sampling rate of 24,000 samples per second in stereo (2 channels) consumes $2 \times 24,000 \times 2 = 96,000$ bytes per second. With 128 GB total capacity, an SD memory card of this size can record up to 128,000,000,000 divided by 96,000 = 1,333,333 seconds, or about 370 hours of recording time.

NOTE: The largest recording file size allowed is 2.0 GB. The recorder automatically breaks up large recordings into smaller segments to satisfy this requirement.

In most applications, there is no reason to use sampling rates faster than twice the frequencies of interest. The majority of frog vocalizations are under 4 kHz and need only be sampled at 8 kHz while most bird vocalizations are under 8 kHz and need only be sampled at 16 kHz (with the exception of some high-pitched warblers who sing at 12 kHz and need to be sampled at 24 kHz).

The following tables estimate the recording time in hours for different combinations of memory capacity, sample rates, and channels:

Estimated Recording Time in Hours [Mono (1 channel)]

	96,000	48,000	44,100	32,000	24,000	22,050	16,000	8,000	4,000
8 GB	11.6	23.1	25.2	34.7	46.3	50.4	69.4	138.9	277.8
16 GB	23.1	46.3	50.4	69.4	92.6	100.8	138.9	277.8	555.6
32 GB	46.3	92.6	100.8	138.9	185.2	201.6	277.8	555.6	1111.1
64 GB	92.6	185.2	201.6	277.8	370.4	403.1	555.6	1111.1	2222.2
128 GB	185.2	370.4	403.1	555.6	740.7	806.2	1111.1	2222.2	4444.4
256 GB	370.4	740.8	806.4	1111.2	1481.6	1612.4	2222.4	4444.4	8888.8

Estimated Recording Time in Hours [Stereo (2 channels)]

	96,000	48,000	44,100	32,000	24,000	22,050	16,000	8,000	4,000
8 GB	5.8	11.6	12.6	17.4	23.1	25.2	34.7	69.4	138.9
16 GB	11.6	23.1	25.2	34.7	46.3	50.4	69.4	138.9	277.8
32 GB	23.1	46.3	50.4	69.4	92.6	100.8	138.9	277.8	555.6
64 GB	46.3	92.6	100.8	138.9	185.2	201.6	277.8	555.6	1111.1
128 GB	92.6	185.2	201.6	277.8	370.4	403.1	555.6	1111.1	2222.2
256 GB	185.2	370.4	403.2	555.6	740.8	806.2	1111.2	2222.2	4444.4

If you enable compression, you can typically increase recording capacity by 40% (compression rates vary with sample rates and site-specific ambient sound levels).

NOTE: Compression consumes more processing power and offers decreased value as memory card prices fall while capacities continue to grow. For most wildlife recording projects, we recommend .wav format.

7.2.3 Mixed Acoustic and Ultrasonic Recording

Estimating mixed recording schedules can be very difficult. Use the *SM3 Configurator* to determine battery longevity. The software understands the power used in both recording modes and can easily generate a calendar showing you a good estimate.

8 Audio Recordings

8.1 Filenames for Recordings

Audio recording files are saved in a **Data** folder on each memory card and use the following naming conventions:

PREFIX_XXX_YYYYMMDD_HHMMSS.wav

PREFIX

The prefix set by the program file or the SM3BAT hardware.

XXX

The channel indicator for each recording. Possible values include:

- `_0_` Mono on channel 0.
- `_1_` Mono on channel 1.
- `0+1` Stereo (both channel 0 and 1).

Triggered .wav recordings record on both channels regardless of which channel caused the trigger. This part of the file name indicates which channel caused the trigger.

NOTE: Triggered .wac recordings are made only on the channel that caused the trigger. This part of the file name indicates the channels that were armed for triggered recording.

YYYYMMDD_HHMMSS

The full timestamp including the year, month, day, hour, minute, and second when the recording started.

.wav

The filename suffix.

- .wav for uncompressed files
- .wac for the proprietary lossless compression WAAC audio format

NOTE: If your recording was saved from a device with a GPS synchronization capability, the file name shows a \$ between the date and time. For example:

ARIZONA-1234_0+1_20161023\$195550.wac

8.2 Recording Metadata

Values for the attributes listed below are stored as metadata in your recording files when recording in .wav format. These metadata tags are helpful in compiling metrics or troubleshooting issues, especially in multi-unit deployments. For example, recordings from a specific device, identified by serial number, can be traced to determine what settings and programs were used during the recording.

Some of the metadata information is visible in the available Kaleidoscope software. Kaleidoscope software has the ability to add further metadata relating to analysis of the recording.

NOTE: Some of the metadata tags described below are only used by Wildlife Acoustics for diagnostics, while others may be used to provide future capabilities and are not currently available.

Device Model

The device model. For example, SM3 or SM3BAT.

Device Serial Number

The unique serial number for your recorder.

Firmware Version

The firmware version installed on the source recorder.

Device Name

The prefix assigned on the recorder under the **Settings** menu.

Timestamp

The date and time when the recording started.

GPS Coordinates

The location of the recorder when recording first started.

Program and Settings

A block of metadata containing the entire program and settings.

TIP: Open the recording in the SM3 Configurator to view the program and settings used to make the recording.

8.3 Summary Text Files

Once per minute during a recording, and when each recording file ends, the SM3BAT appends a line of text to the summary text (.txt) file. It is in comma-separated format (CSV) and you can open it in Excel or in a text editor. The file begins with a header line which identifies the fields that appear in each line of summary data in the rest of the file:

```
DATE, TIME, LAT, , LON, , STEP, POWER(V), TEMP(C), #FILES, #SCRUBBED, MIC0
TYPE, MIC0 TRIGGERS, MIC0 ZCFILES, MIC1 TYPE, MIC1 TRIGGERS, MIC1 ZCFILES
```

As examples, three lines from a sample summary file appear below:

```
2016-Jan-22,17:15:24,42.00000,N,71.00000,W,0.000000,5.9,12.00,2,1,U1,29,0,U1,19,0
2016-Jan-22,17:16:38,42.20000,N,71.10000,W,0.000000,5.9,11.75,3,4,U1,34,0,U1,21,0
2016-Jan-22,17:17:47,42.35000,N,71.18200,W,0.300000,5.5,11.75,1,2,U1,21,0,U1,11,0
```

Date

The date for these entries was January 22, 2016.

Time

The current local time for each entry appears about one minute from the last entry.

NOTE: The date, time, and time zone are set on the recorder.

Latitude and Longitude

If the GPS receiver is installed, the coordinates are given.

Step

The step represents the drift between the GPS time base and internal real time clock. It is only useful for advanced time synchronization calculations.

Power

The power supply voltage for the internal batteries or an external power source appears.

Temperature

In our example, the internal temperature has fallen from 12.0 to 11.75 degrees Celsius.

Number of Files and Scrubbed Files

The values 2, 3, and 1 represent the number of recording files written since the previous summary line.

The values 1, 4, and 2 represent the number of files scrubbed since the previous summary line.

Channel 0 Microphone Type, Triggers, and ZC Files

The channel 0 microphone type: A1, U1, H1, or NA if no microphone is connected on that channel or if channel 0 has been set to an internal mic (not available on SM3BAT units).

The number of channel 0 triggers detected in triggered mode. A zero (0) appears for continuous mode.

The number of zero crossing files written on channel 0. A zero (0) appears when you are not recording in ZC mode.

Channel 1 Microphone Type, Triggers, and ZC Files

The channel 1 microphone type: A1, U1, H1, or NA if no microphone is connected on that channel or if channel 1 has been set to an internal mic (not available on SM3BAT units).

The number of channel 1 triggers detected in triggered mode. A zero (0) appears for continuous mode.

The number of zero crossing files written on channel 1. A zero (0) appears when you are not recording in ZC mode.

8.4 How to Install the Kaleidoscope Software

The free version of the Kaleidoscope post-processing software from Wildlife Acoustics can convert .wac, .wav, and Zero Crossing formats while filtering out unwanted signals. Upgrade to Kaleidoscope Viewer to view spectrograms of your bat recordings. Upgrade to Kaleidoscope Pro to add automatic classification of bats (includes Kaleidoscope Viewer).

1. Navigate to www.wildlifeacoustics.com/support/download-software.
2. Find the file appropriate for your operating system.
3. On Windows, open file and follow installation instructions. On Mac copy the file to the **Applications** folder.

9 Utilities

9.1 How to Erase and Format SD Memory Cards

This procedure erases and formats all installed memory cards. Use this procedure prior to all deployments for optimal performance.

WARNING: This procedure erases all data files on all memory cards in all slots. Verify that you have imported, saved, or copied any important programs, backed up any important recordings, and updated any firmware files before running this utility.

1. At the **Song Meter Main Menu**, select **Utilities**, and press **ENTER/MENU**.
2. Select **Format all cards** and press **ENTER/MENU**.
3. At the **Confirm: Format All?** prompt, choose one of the following options:
 - Press **▶ Right** to select **No** and cancel this entire procedure. Any existing data files remain on the memory cards.
 - Press **▼ Down** to select **Yes** and press **ENTER/MENU** to format all current memory cards in slots A, B, C, and D.
4. If you select **Yes**, the progress of each card in each slot appears and then the screen resets to the last selected submenu.
5. With up to four clean formatted memory cards, you now have the maximum available space on all cards and are ready to start a program and save recordings.

9.2 How to Reset Factory Default Settings

This short procedure restores the original device settings set as default values in the factory when your recorder was first assembled and tested.

1. At the **Song Meter Main Menu**, select **Utilities**, and press **ENTER/MENU**.
2. Select **Set factory default** and then press **ENTER/MENU**.
3. The original settings are restored.

CAUTION: Any custom settings, including solar calculation method, location, and prefix, are erased.

9.3 How to Measure Microphone Sensitivity

You can view and verify the sensitivity of acoustic and ultrasonic microphones. This utility displays dB (re full scale) of both types of microphone.

1. At the **Song Meter Main Menu**, select **Utilities**, and press **ENTER/MENU**.
2. Select **Calibrate Mics** and then press **ENTER/MENU**.

MICROPHONE CALIBRATE	
@1	@40 kHz
Ch 0: -62.4	-73.8 dB
Ch 1: -62.5	-73.6 dB

- a. The values under @1 represent levels at 1 kHz, a good measure of acoustic sensitivity.
 - b. The values under @40 are for testing the SM3/SMM-U1 with the available Ultrasonic Calibrator.
3. Press **ENTER/MENU** when finished.
 - To test SMM-A1 microphones, you can also generate a 1 kHz signal with a professional microphone calibrator (which slides over the mic), or use a signal generation smartphone app played in proximity. To set both microphones at approximately the same sensitivity, adjust the GAIN level in your program to better match the microphones.
 - To test SM3/SMM-U1 microphones, order the Ultrasonic Calibrator.

9.3.1 How to Use the Ultrasonic Calibrator

Use the available Ultrasonic Calibrator for the SM3BAT to calibrate SM3/SMM-U1 microphones. Since ultrasound is beyond the range of human hearing, verifying proper system and microphone performance can be a challenge. The Ultrasonic Calibrator helps you test both the microphone and the full recorder system.

The battery door is located at the top of the unit. When the battery can no longer power the device the LED will not illuminate and no sound will be emitted. The volume of the emitted sounds will not decrease as the battery is depleted. If the LED is lit at all, then the calibrator is operating normally.

The calibrator has two modes of operation:

- **CAL:** Calibration mode is used to test the microphone at close range.
- **CHIRP:** Chirp mode is used to test the entire system at a greater distance.

9.3.2 Calibration Mode

To test a microphone, the calibrator generates a calibrated 40 kHz tone.

1. Attach the microphone to either microphone port using a microphone extension cable.
2. At the **Song Meter Main Menu**, select **Utilities**, and press **ENTER/MENU**.
3. Select **Calibrate Mics** and then press **ENTER/MENU**.
4. Install the clear calibrator microphone adapter by sliding it onto the calibrator from the bottom (the end with the Wildlife Acoustics logo) until it is touching the toggle switches.



5. Place the microphone in the calibrator microphone adapter. Make sure that the side with the smaller hole diameter is near the toggle switches. Insert the microphone until it rests against the smaller opening of the adapter hole.





6. Turn the calibrator **ON** and set the mode switch to **CAL**.
7. The SM3 displays the received signal level below the @40 for each channel.
8. Compare the signal level to the microphone specification. Microphone sensitivity is affected by orientation. Rotate the microphone very slowly 360 degrees and note the largest (least negative) number:
 - A higher (less negative) number indicates a more sensitive microphone.
 - A lower number indicates some loss of sensitivity.
 - If the value is less (more negative) than **-38 dB** your microphone has lost some or all of its sensitivity.

9.3.3 Chirp Mode

To test the SM3BAT system, the Ultrasonic Calibrator can emit loud ultrasonic signals to the recorder while it is recording from some distance. Analyze these recordings to verify that the recorder settings are appropriate and the system is functioning as expected.

1. Remove the microphone adapter from the calibrator.



2. Set the toggle switch to **CHIRP**.
3. The unit emits a 40 kHz pulsed signal at very high amplitude. The signal can be picked up by the SMM-U1 microphone and seen in the recording at distances up to about 20 meters.

WARNING: Do not place the Ultrasonic Calibrator near your ears! In **CHIRP** mode, the calibrator emits a 40 kHz signal at over 100 dB SPL. Prolonged exposure to high intensity ultrasonic signals may cause permanent hearing loss at audible frequencies.

9.4 How to Update the Firmware

When a new firmware update is available, download and install it to update your recorder components. You must register online to access the downloads.

1. On your computer or mobile device, open a web browser.
 2. Navigate to www.wildlifeacoustics.com.
 3. Click **Support** and then click **Downloads**.
 4. Complete the online form and click **Request Downloads**.
 5. Select the latest SM3BAT firmware update file to download it.
 6. (Optional) As a registered user, you can also access the following downloads:
 - SM3 Configurator
 - Kaleidoscope software for sound file conversions
 - Song Scope software
 - Firmware for other devices such as Echo Meter or SM2
 7. Save or copy the .SM3 firmware file to the top level of an SD card.
 8. Turn each of the four thumb-screws ⤴ counterclockwise and remove the cover to the memory bay.
 9. Insert the SD card into slot A of the recorder.

NOTE: Perform all firmware updates on an SD card in memory slot A. The **Firmware Update** menu option waits for a card to be inserted in slot A.

10. At the **Song Meter Main Menu**, press **▼ Down** to select **Utilities** and then press **ENTER/MENU**.
11. Press **▼ Down** to select **Firmware Update** and then press **ENTER/MENU**.

NOTE: You can also press and hold **▲ Up** while powering the unit **ON** to activate the firmware update menu.

12. The recorder scans your SD card in slot A for valid .SM3 files.

- At the **Select upgrade file** prompt, select the firmware update file that you want to apply and press **ENTER/MENU**. The following message appears:

```
Upgrading.....  
UPGRADE COMPLETE  
Rebooting
```

The system applies the new firmware and restarts.

9.5 How to Generate Diagnostics

Use this procedure to generate diagnostic information about the current state of the recorder. Use the diagnostic information to troubleshoot any problems you may be experiencing. When contacting customer support, a representative may ask you to provide this information to diagnose the problem.

- Insert at least one SD card into the recorder.
- At the **Song Meter Main Menu**, select **Utilities**, and press **ENTER/MENU**.
- Select **Export Diagnostics** and then press **ENTER/MENU**.
- The unit performs audio path tests and then exports the following information in a log file to the first available SD card:
 - current settings
 - current configurations
 - current program
 - other diagnostic information

Note: You can also press and hold **▼Down** while powering the unit **ON** to activate the diagnostics utility.

The diagnostic file name ends in an `.sm3dump` extension and includes the location prefix, date, and time. For example:

```
ARIZONA-1234_20160106_215045.sm3dump
```

10 SM3BAT Specifications

10.1 Physical

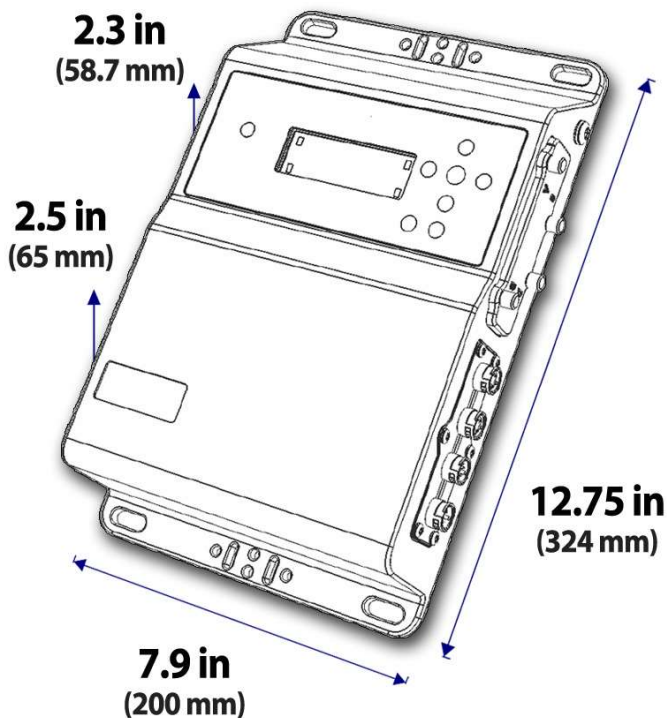

SM3BAT Physical Specifications

Length/Height: 12.75 inches (32.4 cm)
Width: 7.875 inches (20.0 cm)
Depth (Upper): 2.31 inches (58.7 cm)
Depth (Lower): 2.56 inches (65.0 cm)
Weight: 5.5 pounds (2.5 kg)
Weight (with 4 Batteries): 7.0 pounds (3.2 kg)
Operating Temperature: -4°F to 122°F (-20°C to 50°C)

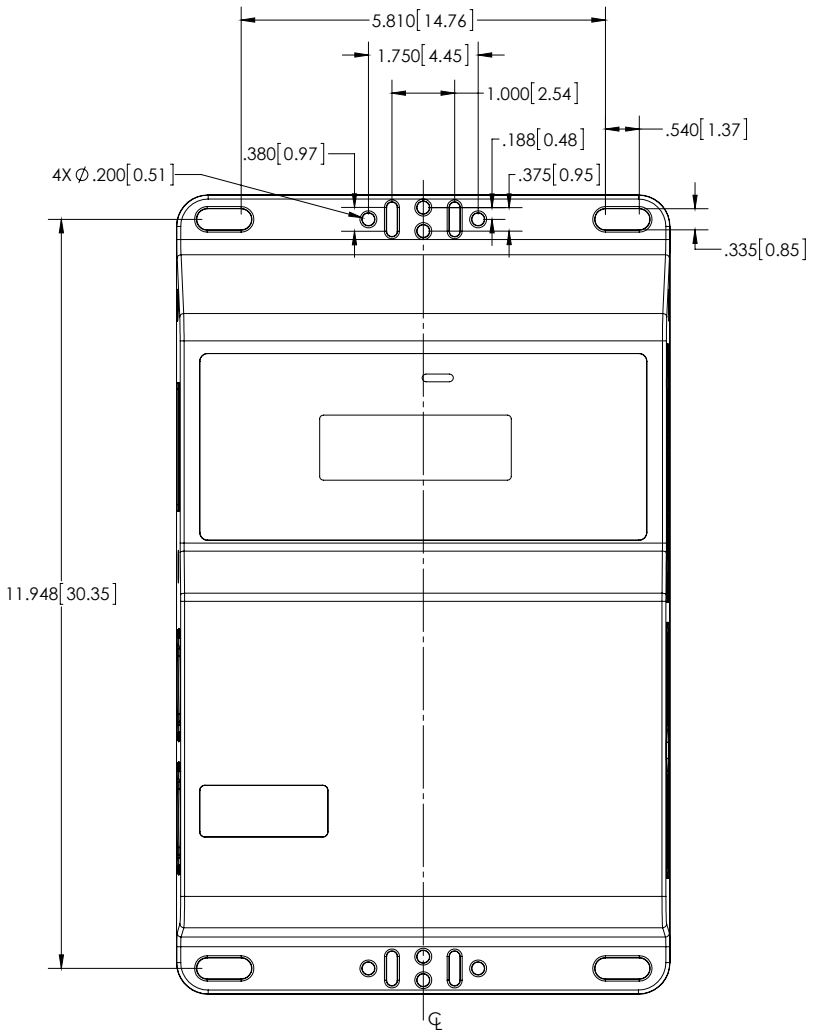

10.2 Power

Main Power: 4.5 - 17V DC (4 internal D-size batteries)

External Power Connector: 5 to 17V DC

Clock Backup Battery Type: CR2032 (up to 8-year life)

Power Consumption: 0.5 mW (sleeping); 250 – 800 mW (recording)

Battery Specifications: The recorder uses four (4) standard D size disposable alkaline batteries, rechargeable NiMH batteries, or batteries. Battery life can vary widely depending on the battery type, brand, charger, temperature, and other factors. The following battery life cycles are typical and assume 10-hour nights and nap mode activated for full spectrum:

- Alkaline batteries (estimated 12,000 milliamp hours at 1.5V each):
 - Full spectrum on 1 channel: 18 nights
 - Full spectrum on 2 channels: 15 nights
 - Zero crossing on 1 channel: 20 nights
 - Zero crossing on 2 channels: 15 nights
- NiMH batteries (estimated 10,000 milliamp hours at 1.2V each):
 - Full spectrum on 1 channel: 12 nights
 - Full spectrum on 2 channels: 10 nights
 - Zero crossing on 1 channel: 13 nights
 - Zero crossing on 2 channels: 10 nights

10.3 Memory Cards

The four (4) memory card slots can be populated with at least one (1) and up to four (4) memory cards of assorted capacities. The device supports all class 4 or faster SDHC or SDXC cards.

Memory Sizes: Up to 1.0 terabyte (1024 gigabytes) supported total capacity using 256 GB SDXC memory cards for all four (4) memory slots. This is the maximum currently available; higher capacities may be available in the future.

Formats: FAT32 for SDHC or exFAT for SDXC

Compression typically increases effective capacity by 40%.

10.4 Acoustic Audio

Channels: 2

Recording format: 16-bit PCM .wav or optional .wac proprietary lossless compressed format

Analog to Digital Converter: 0.707V RMS (2v p-p) full-scale

Amplifier Gain: 0 dB – 59.5 dB in 0.5-dB steps

Noise Floor: -134 dBfs/sqrt(Hz) @48 kHz rate, 1 K input impedance, 0 dB gain

High Pass Filter: Optional 2-pole at 220 Hz or 1 kHz

Sample Rates: The recorder supports the following sample rates in samples per second on one or two channels:

- 1000
- 2000
- 4000
- 8000
- 9600
- 12000
- 16000
- 19200
- 24000
- 32000
- 48000
- 96000

Anti-alias filter gain:

- From 0 to 0.39 sample rate: ± 0.1 dB
- At 0.4125 sample rate: -0.25 dB
- At 0.45 sample rate: -3 dB
- At 0.5 sample rate: -17.5 dB
- From 0.55 to 64 sample rate: -75 dB

10.5 Ultrasonic Audio

Channels: 2

Recording format: 16-bit PCM .wav or optional .wac proprietary lossless compressed format or zero crossing

Analog to Digital Converter: 0.884V RMS (2.5v p-p) full-scale

Amplifier Gain: 0 dB or 12 dB

Noise Floor: -116 dBfs / sqrt(Hz) @ 384 kHz sample rate, 1K input impedance, 0dB gain

High Pass Filter: Optional 4-pole at 16 kHz

Sample Rates: The recorder supports the following rates in samples per second:

- WAC recording
 - 192000 (one or two channels)
 - 384000 (one channel)
- WAV recording
 - 192000 (one or two channels)
 - 256000 (one or two channels)
 - 384000 (one channel)

Anti-alias filter:

- 2-pole at 128 kHz for 192 kHz and 256 kHz sample rates
- 2-pole at 192 kHz for 384 kHz sample rate

10.6 Microphones

10.6.1 SMM-U1 Ultrasonic

Enclosure: Weatherproof stainless steel

Directionality: Omnidirectional

Element: Knowles FG

Output: Differential

Built in high pass filter: 4-pole at 8 kHz

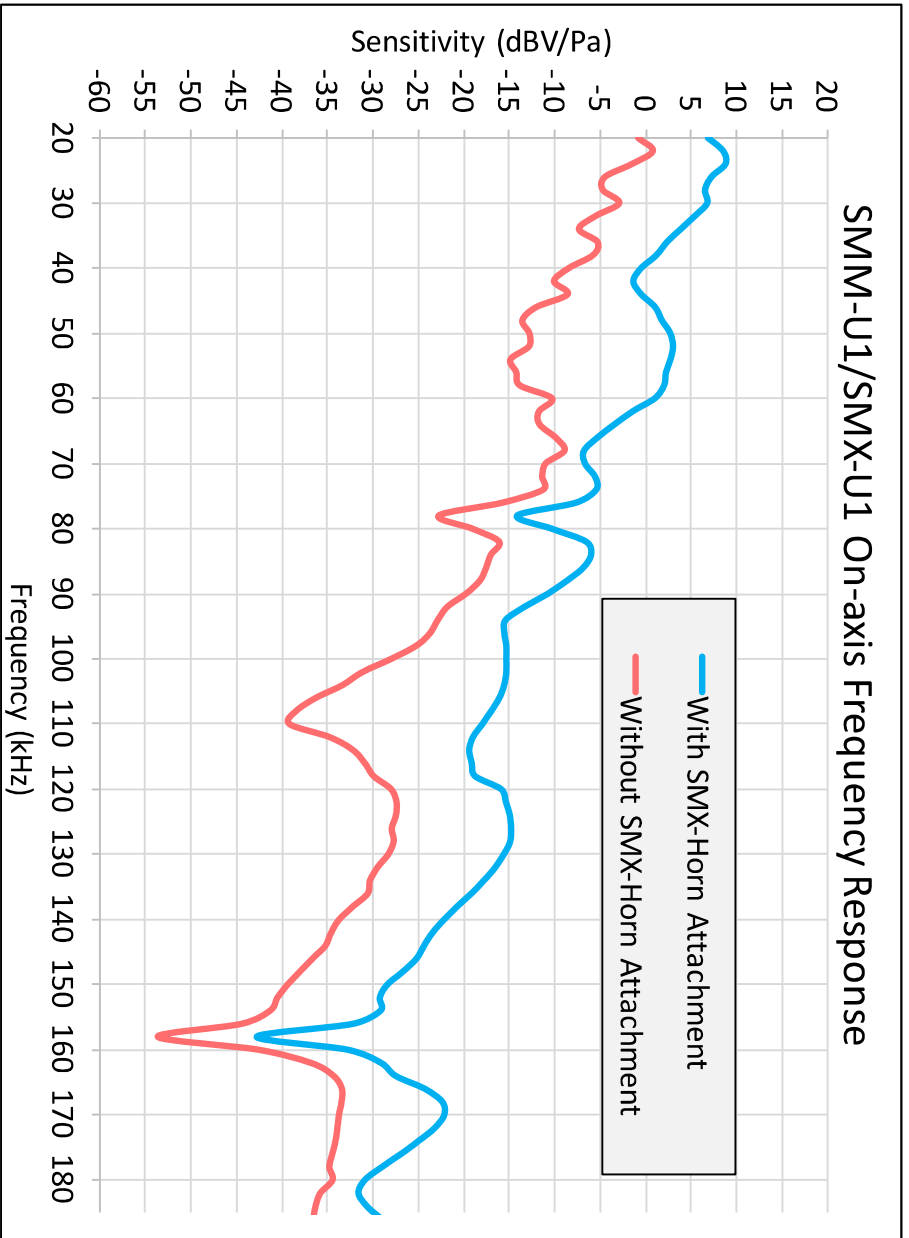

SMM-U1/SMX-U1 Directional Response without SMX-Horn

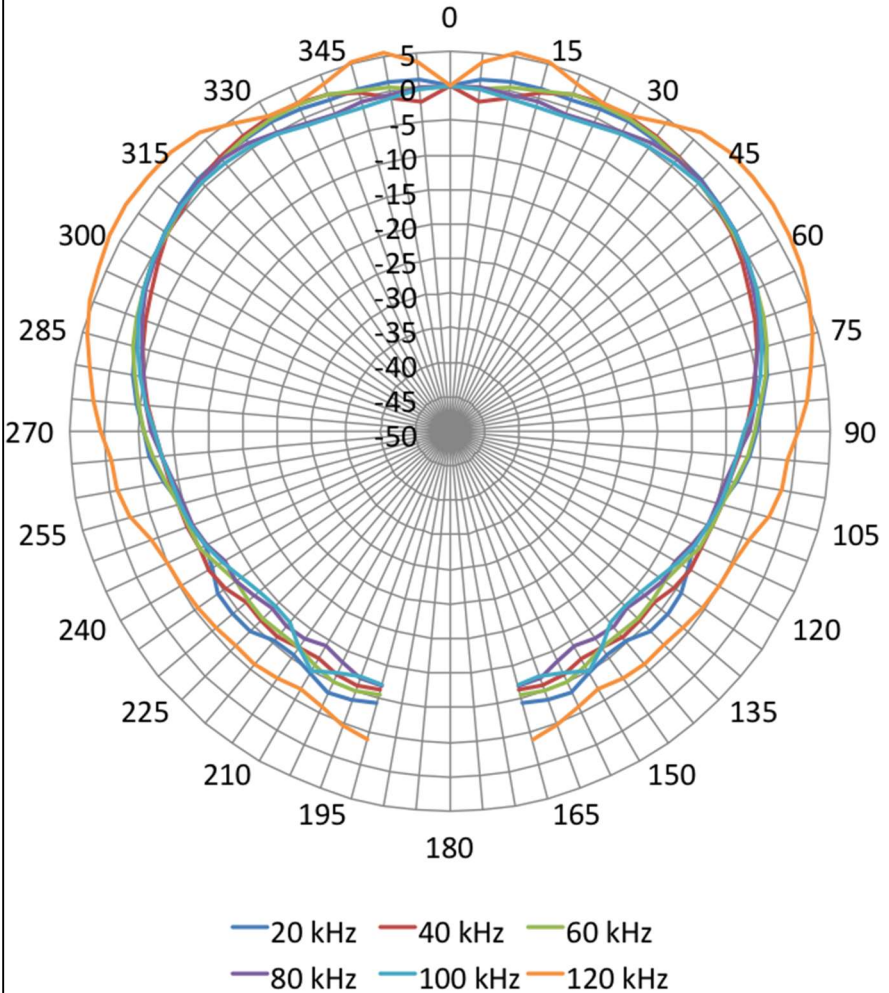

SMM-U1/SMX-U1 Directional Response with SMX-Horn

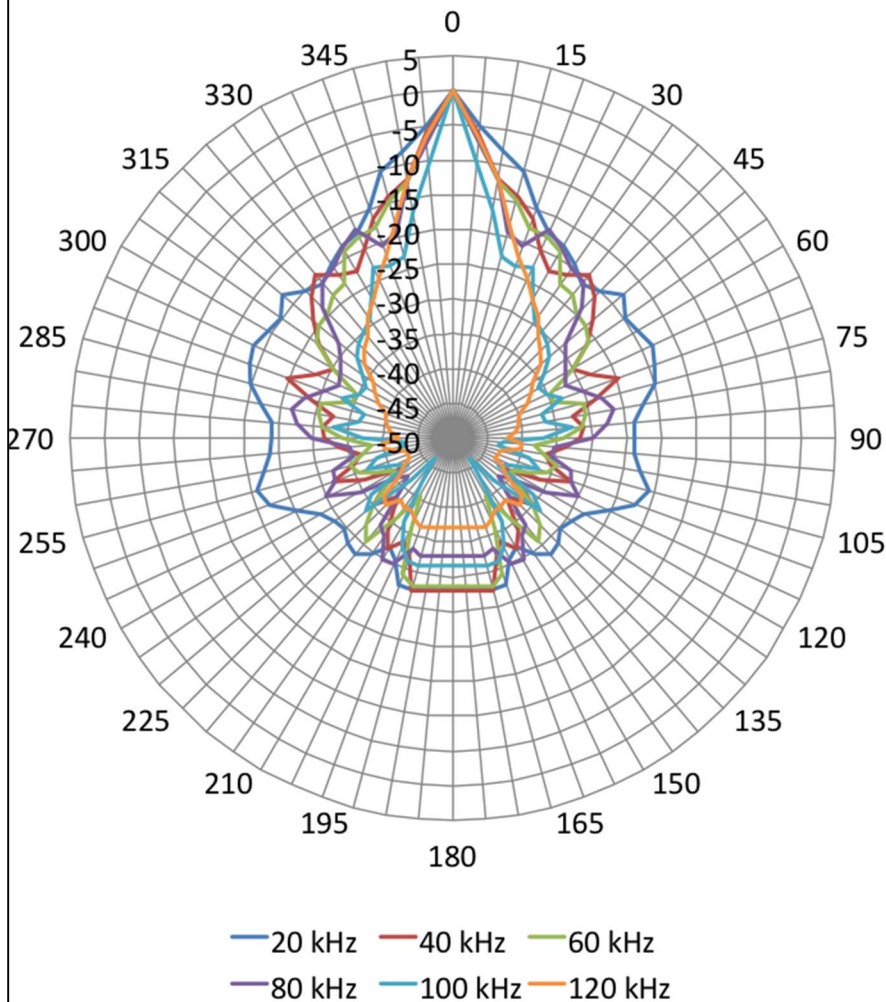

10.6.2 SMM-A1 Acoustic

Enclosure: Weatherproof ruggedized anodized aluminum

Sensitivity: -11 ± 4 dB (0dB=1V/pa@1KHz)

Signal-to-Noise Ratio: > 68 dB

Dynamic Range: 26dB - 102dB SPL at 0dB gain

Directionality: Omnidirectional

Output: Differential

Frequency Response: Flat (± 10 dB) from 50 Hz to 20 kHz

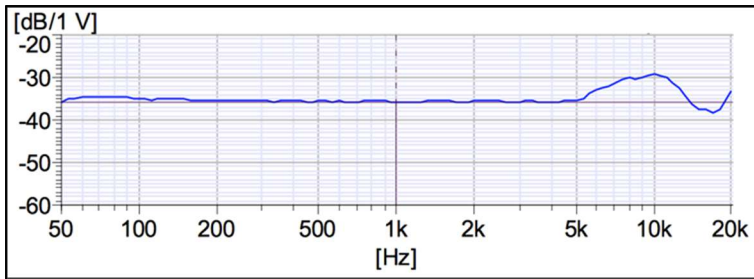

11 Warranty and Disclosures

Except as specifically provided herein, Wildlife Acoustics makes no warranty of any kind, express or implied, with respect to this product.

11.1 Wildlife Acoustics, Inc. Limited Warranty

Hardware: Wildlife Acoustics, Inc. (“WAI”) warrants to the original end user (“Customer”) that new WAI branded products will be free from defects in workmanship and materials, under normal use. Refer to the following table for the applicable warranty period from the original date of purchase.

Hardware Limited Warranty

Product	Components	Hardware Warranty Period
SM3 and SM3BAT Recorders	All components (excluding microphones, batteries and accessories)	3 Years
SM3 and SM3BAT Recorders	Microphones, batteries and accessories	1 Year
Other WAI products	All components	1 Year

WAI warrants refurbished WAI products, marked and sold as such, for ninety (90) days from the original purchase date.

Software: WAI warrants to Customer that any WAI branded software will perform in substantial conformance to their program specifications for a period of ninety (90) days from the date of original purchase. WAI warrants the media containing software against failure during the warranty period. WAI makes no warranty or representation that the operation of the software products will be uninterrupted or error free, or that all defects in the software products will be corrected.

Exclusions: This warranty excludes (1) physical damage to the surface of the product, including cracks or scratches on the outside casing; (2) damage caused by misuse, neglect, improper installation or testing, unauthorized attempts to open, repair, or modify the product, or any other cause beyond the range of the intended use; (3) damage caused by accident, fire, power changes, other hazards, or acts of God; or (4) use of the product with any non-WAI device or service if such device or service causes the problem.

Any third party products, including software, included with WAI products are not covered by this WAI warranty and WAI makes no representations or warranties on behalf of such third parties. Any warranty on such products is from the supplier or licensor of the product.

No warranty is provided by WAI unless the product was purchased from an authorized distributor or authorized reseller.

Exclusive Remedies: Should a covered defect occur during the warranty period and you notify WAI, your sole and exclusive remedy shall be, at WAI’s sole option and expense, to repair or replace the product or software. If WAI cannot reasonably repair nor replace then WAI may, in its sole discretion, refund the purchase price paid for the product. Replacement products or parts may be new or reconditioned or comparable versions of the defective item. WAI warrants any replaced or repaired product, part, or software for a period of ninety (90) days from shipment, or through the end of the original warranty, whichever is longer.

Obtaining Warranty Service: Customer should refer to the WAI website at www.wildlifeacoustics.com/support/contact-support for information on obtaining warranty service authorization. Methods for obtaining warranty service may vary depending on whether purchases were made from an authorized provider of WAI products or from WAI directly. All requests for warranty service authorization must be made within the applicable warranty period. Dated proof of original purchase will be required. Products or parts shipped by Customer to WAI must be sent postage-paid and packaged appropriately for safe shipment.

WAI is not responsible for Customer products received without a warranty service authorization and may be rejected. Repaired or replacement products will be shipped to Customer at WAI expense. All products or parts that are replaced become the property of WAI. WAI shall not be responsible for Customer software, firmware, information, or memory data contained in, stored on, or integrated with any products returned to WAI for repair, whether under warranty or not. The repair and replacement process for products or parts in locations outside of the United States will vary depending on Customer's location.

Warranties Exclusive: THE FOREGOING WARRANTIES AND REMEDIES ARE EXCLUSIVE AND IN LIEU OF ALL OTHER WARRANTIES, TERMS OR CONDITIONS, EXPRESS, IMPLIED OR STATUTORY, INCLUDING WARRANTIES OF MERCHANTABILITY, FITNESS FOR A PARTICULAR PURPOSE, ACCURACY, CORRESPONDENCE WITH DESCRIPTION, SATISFACTORY QUALITY AND NON-INFRINGEMENT, ALL OF WHICH ARE EXPRESSLY DISCLAIMED BY WAI AND ITS SUPPLIERS.

Limitations of Liability: NEITHER WAI NOR ITS SUPPLIERS SHALL BE LIABLE FOR INCIDENTAL, CONSEQUENTIAL, INDIRECT, SPECIAL, OR PUNITIVE DAMAGES OF ANY KIND, LOSS OF INFORMATION OR DATA, LOSS OF REVENUE, LOSS OF BUSINESS OR OTHER FINANCIAL LOSS ARISING OUT OF OR IN CONNECTION WITH THE SALE OR USE OF THIS PRODUCT, WHETHER BASED IN CONTRACT, TORT (INCLUDING NEGLIGENCE), STRICT PRODUCT LIABILITY OR ANY OTHER THEORY, EVEN IF WAI HAS BEEN ADVISED OF THE POSSIBILITY OF SUCH DAMAGES AND EVEN IF ANY LIMITED REMEDY SPECIFIED IN THIS LICENSE AGREEMENT IS DEEMED TO HAVE FAILED OF ITS ESSENTIAL PURPOSE. WAI'S ENTIRE LIABILITY SHALL BE LIMITED TO REPLACEMENT, REPAIR, OR REFUND OF THE PURCHASE PRICE PAID, AT WAI'S OPTION. IN NO EVENT SHALL WAI'S LIABILITY FOR ALL DAMAGES RELATED TO THE PURCHASE OF PRODUCT EXCEED THE AMOUNT PAID FOR THE APPLICABLE PRODUCT. THE FOREGOING LIMITATIONS WILL APPLY EVEN IF THE ABOVE STATED REMEDY FAILS OF ITS ESSENTIAL PURPOSE.

Disclaimer: Some countries, states, or provinces do not allow the exclusion or limitation of implied warranties or the limitation of incidental or consequential damages so the above limitations and exclusions may be limited in their application to you. When implied warranties may not be excluded in their entirety, they will be limited to the duration of the applicable written warranty. This warranty gives you specific legal rights; you may have other rights that may vary depending on local law. Your statutory rights are not affected.

Governing Law: This Limited Warranty shall be governed by the laws of the Commonwealth of Massachusetts, U.S.A., and by the laws of the United States, excluding their conflicts of laws principles. The United Nations Convention on Contracts for the International Sale of Goods is hereby excluded in its entirety from application to this Limited Warranty.

Wildlife Acoustics, Inc.

3 Clock Tower Place, Suite 210

Maynard, MA 01754-2549 United States of America

www.wildlifeacoustics.com

February 26, 2014

11.2 Declaration of Conformity (EN 45014)

Manufacturer:

Wildlife Acoustics, Inc.
3 Clock Tower Place, Suite 210
Maynard, MA 01754
United States of America



Declares that the following product:

Product Name: Song Meter
Product Model Number: SM3BAT
Product Type: Bioacoustics Recorder

Conforms to the appropriate country standards and governing regulations listed below and/or on the following page. As the manufacturer, we are fully responsible for the design and production of the above-mentioned equipment.

Federal Communications Commission Rules Part 15, Class A

AS/NZS CISPR 11, 2011, Industrial, scientific and medical (ISM) radio-frequency equipment – electromagnetic disturbance characteristics – limits and methods of measurement, Class A

EN 55011, 2009/A1, 2010, Industrial, scientific and medical (ISM) radio-frequency equipment – Electromagnetic disturbance characteristics – Limits and methods of measurement, Class A

ICES-003, 2004, Industry Canada, Interference-Causing Equipment Standard, Digital Apparatus, Class A

EN61326, 2006 Electrical Equipment for Measurement, Control and Laboratory use EMC Requirements (EMC Directive 2004/108/EC)

EN61000-4-2 Electrostatic Discharge

EN61000-4-3 Radiated Electromagnetic Fields

IEC 60529 Sect. 14.2.5 IPX5, 2002 (Water Jet Test)

IEC 60529 Sect. 14.2.6 IPX6, 2002 (Water Jet Test)

MIL-STD-810G Method 514.6 (US Highway Vibration Test)

ISTA 1A (vibration and shock/drop testing)

Testes at operating temperatures of -20C to +55C. Testing included 24-hour soaks at both extremes plus 6 cycles for one hour each between extremes.

Tested operating humidity 95% RH at +40C. Testing included 24-hour soak.

This product was tested in a typical configuration.



Ian Agranat, President
Wildlife Acoustics, Inc.
March 1, 2014

11.3 Prohibition Against Eavesdropping

United States law (Federal Communications Commission Part 15 Section 15.9) states “Except for the operations of law enforcement officers conducted under lawful authority, no person shall use, either directly or indirectly, a device operated pursuant to the provisions of this Part for the purpose of overhearing or recording the private conversations of others unless such use is authorized by all of the parties engaging in the conversation.”

You are responsible for complying with all applicable laws within your jurisdiction.

11.4 Electromagnetic Interference

This equipment has been tested and found to comply with the limits for a Class A digital device, pursuant to Part 15 of the FCC Rules.

These limits are designed to provide reasonable protection against harmful interference when the equipment is operated in a commercial environment. This equipment generates, uses, and can radiate radio frequency energy and, if not installed and used in accordance with the instruction manual, may cause harmful interference to radio communications. Operation of this equipment in a residential area is likely to cause harmful interference in which case the user will be required to correct the interference at his own expense.

Changes or modifications not expressly approved by Wildlife Acoustics, Inc. could void the user's authority to operate the equipment.

Note: Use of ferrite clamped cables are required to comply with the Class A limits in part 15 of the FCC rules. A Fair-Rite 0431164181 ferrite clamp (or equivalent) must be placed on each cable near the recorder with the ferrite residing within one loop of the cable.

Song Meter SM3BAT

BIOACOUSTICS RECORDER

User Guide

CE FC

Wildlife Acoustics, Inc.

3 Clock Tower Place, Suite 210

Maynard, MA 01754

(978) 369-5225 (888) 733-0200

www.wildlifeacoustics.com

